

NH-PI-Z-D Series

Specification table

Model	Connection Discharge x Suction inch (mm)	Max flow GPM (L/min)	Max head ft (m)	Motor		
				Power (V)	Output x Input (W)	Speed (rpm)
NH-5PI-Z-D	5/16" x 9/16" (8 x 14)	1.6 (6)	14.8 (4.5)	DC24V,DC12V	8 x 13	3700
NH-10PI-Z-D	5/16" x 9/16" (8 x 14)	2.2 (8)	29 (9)	DC24V	18 x 30	5500
NH-15PI-Z-D	5/16" x 11/16" (8 x 18)	2.2 (8)	29 (9)	DC24V	20 x 45	3200
NH-20PI-Z-D	11/16"x11/16" (18 x 18)	4.2 (16)	27 (8.2)	DC24V	30 x 55	3000
NH-30PI-Z-D	11/16"x11/16" (18 x 18)	5.4 (20)	36 (11)	DC24V	45 x 65	3300

Pump performance curve

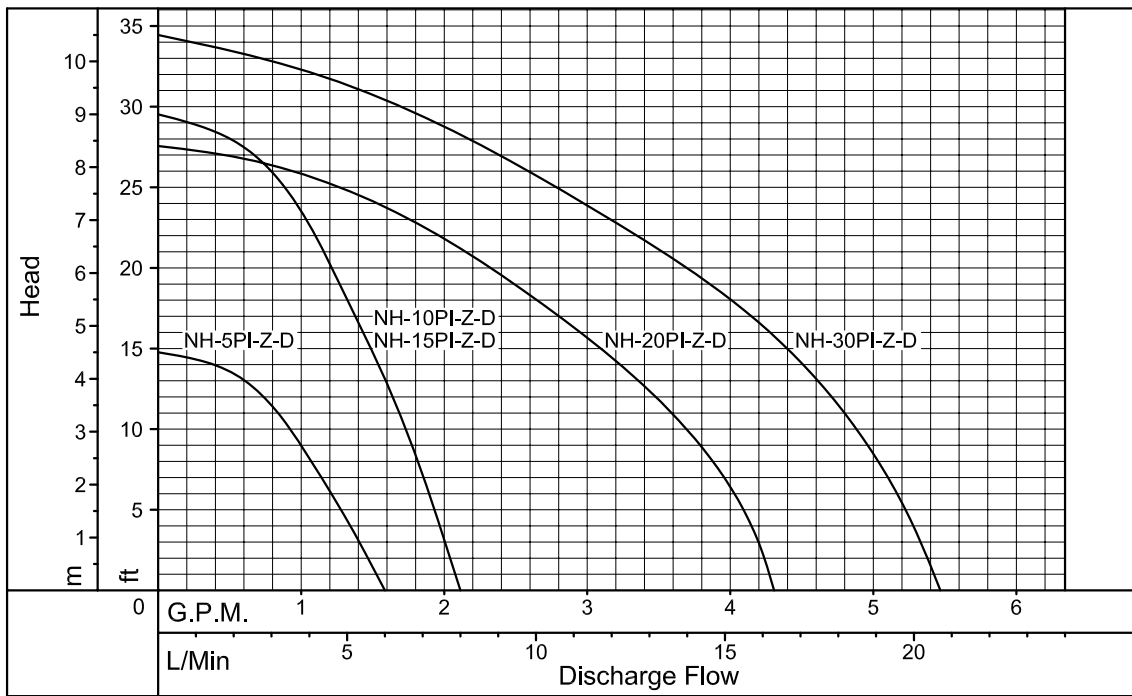

Installation dimension

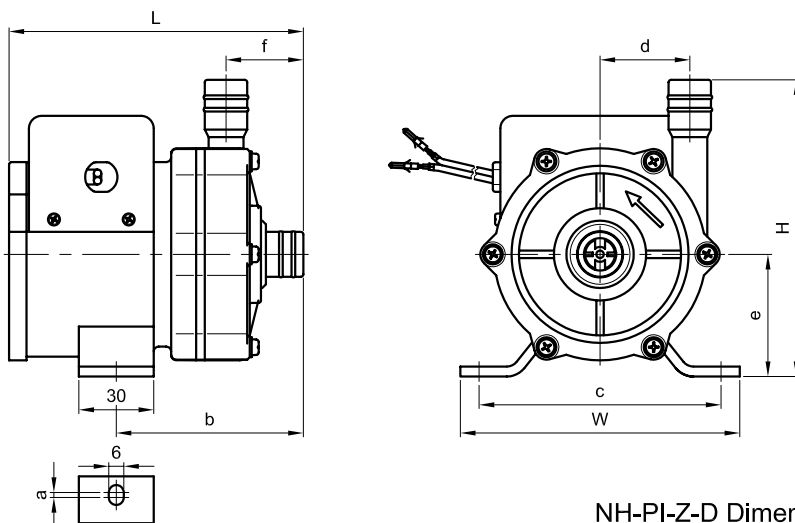

NH-PI-Z-D Dimensions in inch (mm)

Model	W	H	L	a	b	c	d	e	f
NH-5PI-Z-D	2.91" (74)	3.54" (90)	3.94" (100)	0" (0)	2.66" (67.5)	2.36" (60)	0.83" (21)	1.77" (45)	1.04" (26.5)
NH-10PI-Z-D	2.91" (74)	3.54" (90)	3.94" (100)	0" (0)	2.66" (67.5)	2.36" (60)	0.83" (21)	1.77" (45)	1.04" (26.5)
NH-15PI-Z-D	4.41" (112)	4.69" (119)	4.65" (118)	0.08" (2)	2.95" (75)	3.82" (97)	1.42" (36)	1.93" (49)	1.22" (31)
NH-20PI-Z-D	4.41" (112)	4.69" (119)	4.65" (118)	0.08" (2)	2.95" (75)	3.82" (97)	1.42" (36)	1.93" (49)	1.22" (31)
NH-30PI-Z-D	4.41" (112)	4.69" (119)	4.84" (123)	0.08" (2)	2.95" (75)	3.82" (97)	1.42" (36)	1.93" (49)	1.22" (31)