

NO	PART NAME	Q'TY	MATERIAL	NOTE	PART NO.
08	SET SCREW	2	S435	M4X5	
07	SCREW,GROSS RECESS HEAD W/L PLAIN WASHER	6	SUS304	M5X28	
06	O. RING	1	FKM	S80	1001412301
05	OUTER DRIVE RING	1	ADC-12	φ70X63.5	1001212604
04	IMPELLER ASS'Y	1	PPG	φ75X59.5	1001212405
03	REAR CASING	1	PPG	φ91X59.5	1001212405
02	FRONT CASING	1	PPG	HOSE THREAD	1001412300
01	MOTOR	1	45W.2P	100~120V 200~240V	1011212357 1001212357

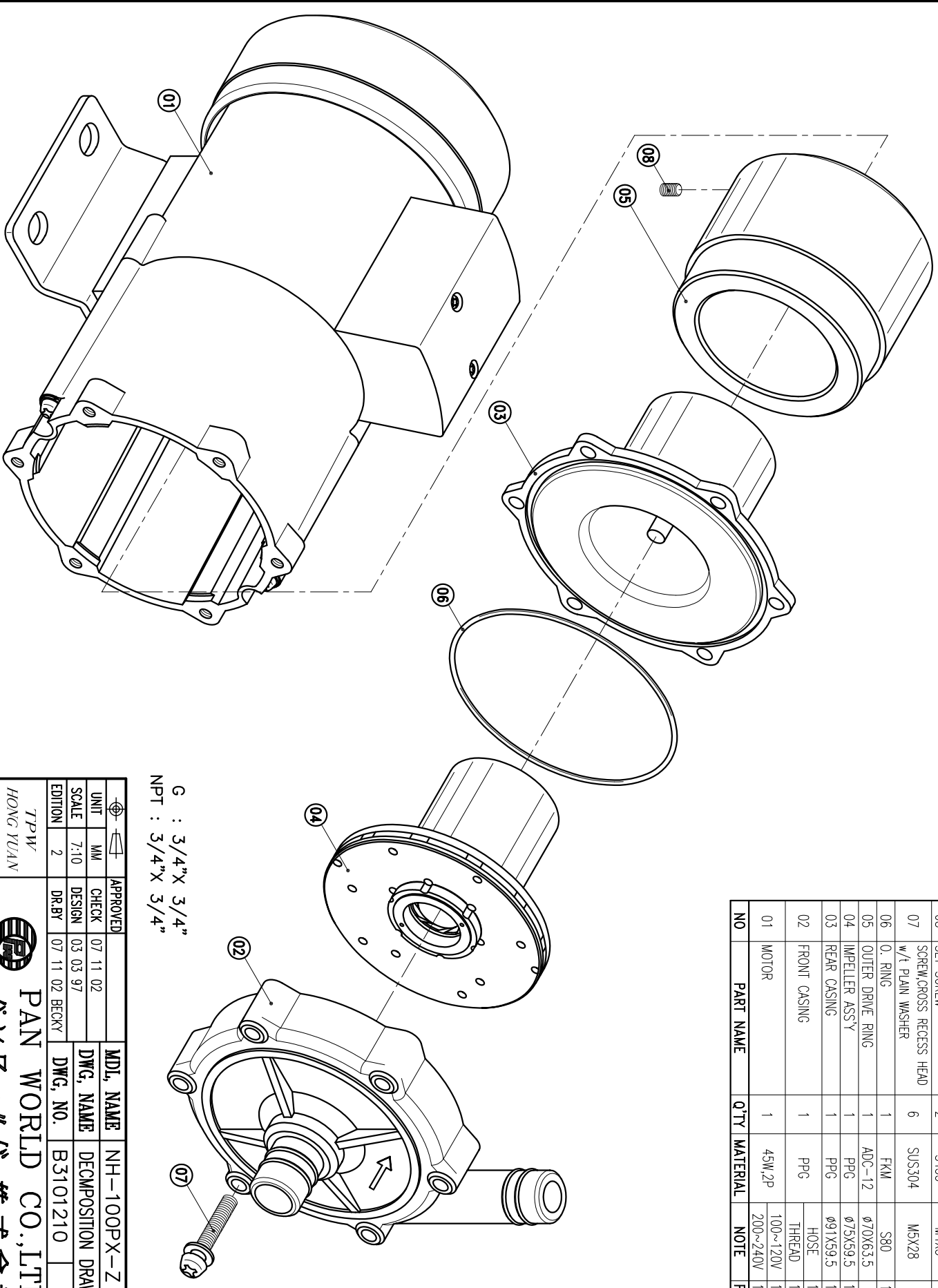

G : 3/4"X 3/4"
NPT : 3/4"X 3/4"

APPROVED	CHECK	DATE	MDL NAME	NH-100PX-Z
TPW	07 11 02		DWG. NAME	DECOMPOSITION DRAWING
HONG YUAN	03 03 97		DWG. NO.	B3101210
	07 11 02 BECKY			A3

PAN WORLD CO.,LTD.
パンワールド株式会社