

NO	PART NAME	Q'TY	MATERIAL	NOTE	PART NO.
09	SET SCREW	2	S435	MAX5	
08	SCREW,GROSS RECESS HEAD W/L PLAIN WASHER	4	SUS304	MAX15	
07	SCREW,GROSS RECESS HEAD W/L PLAIN WASHER	2	SUS304	MAX30	
06	O. RING	1	FKM	S67	1001512311
05	OUTER DRIVE RING	1	ADC-12	φ70X63.5	
04	IMPELLER VANE	1	PPG	φ62X57.5	1001212804
03	REAR CASING	1	PPG	φ80X59.5	1001212505
02-1	FRONT THRUST PAD	1	RLON	φ12X6	1001212313
02	FRONT CASING	1	PPG	HOSE THREAD	1001512310 1011512300
01	MOTOR	1	65W-2P	100~120V 200~240V	1011212377 1001212377

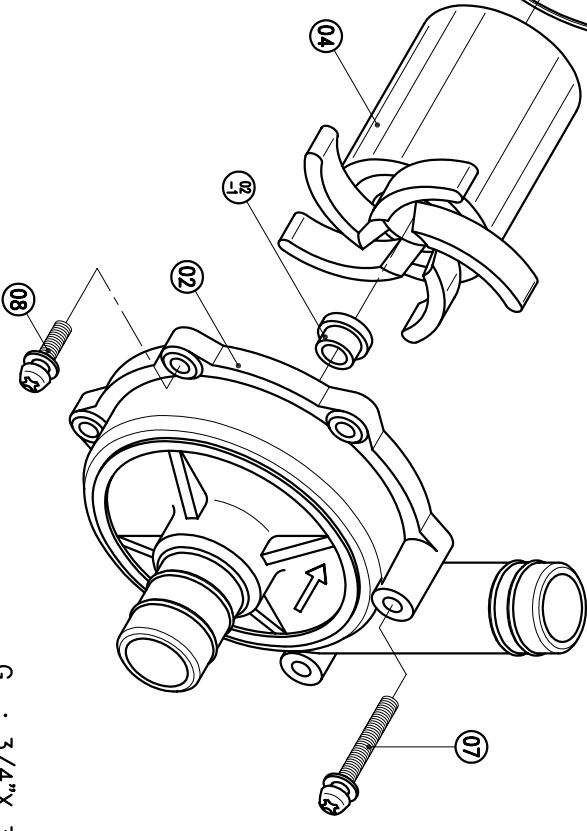
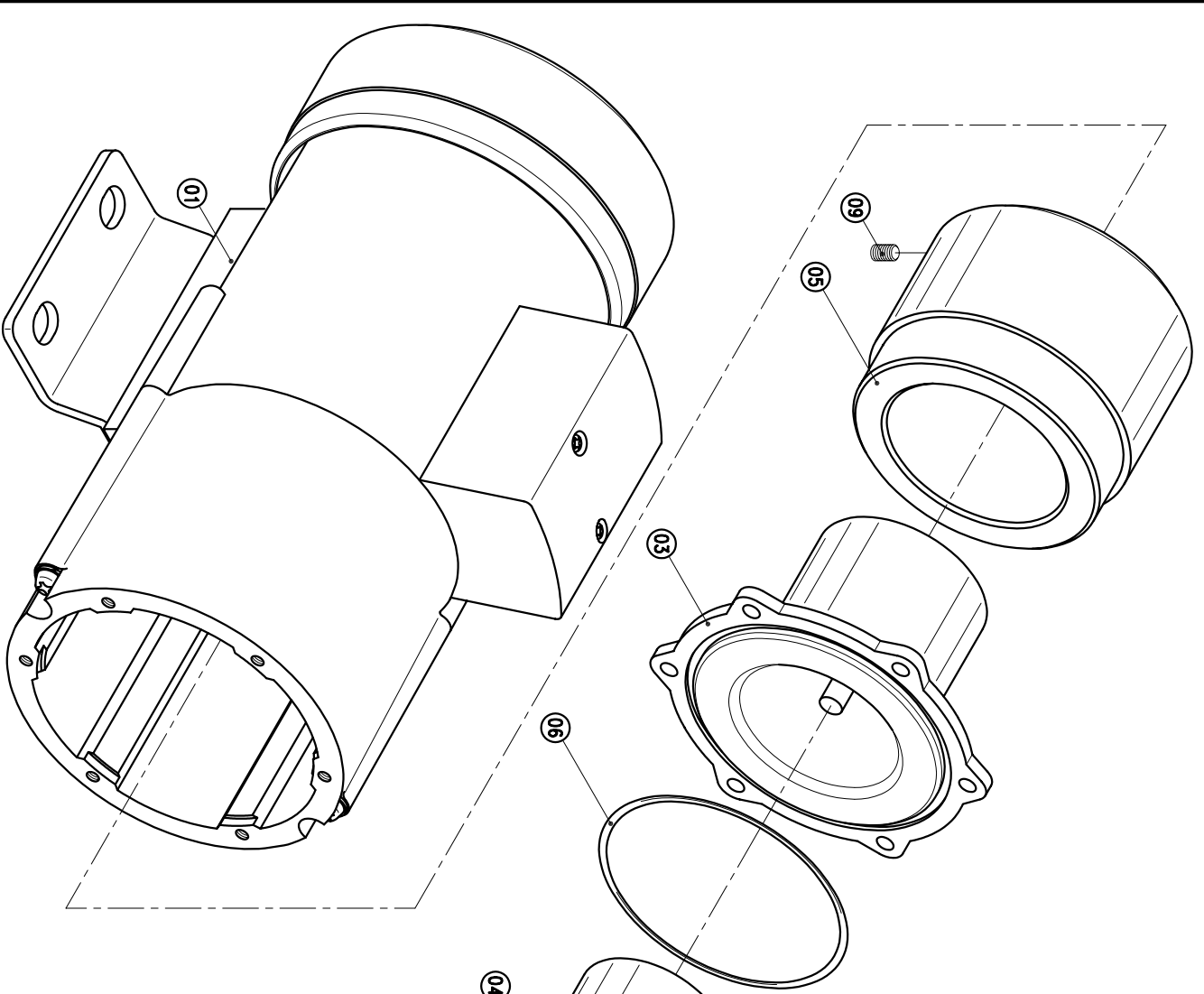

G : 3/4"X 3/4"  
NPT : 3/4"X 3/4"

APPROVED	CHECK	MDL NAME	NH-100PX
07 12 02	07 12 02	DWG, NAME	DECOMPOSITION DRAWING
03 03 97	03 03 97	DWG, NO.	B3101209
07 12 02 BECKY	07 12 02 BECKY		A3

TPW  
HONG YUAN

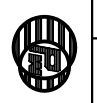

PAN WORLD CO., LTD.  
パンワールド株式会社