

NO	PART NAME	Q'TY	MATERIAL	NOTE	PART NO.
08	SET SCREW	2	S435	MAX5	
07	SCREW,GROSS RECESS HEAD W/L PLAIN WASHER	6	SUS304	M5X28	
06	O. RING	1	FKM	S80	1001412301
05	OUTER DRIVE RING	1	ADC-12	φ70X63.5	1001212504
04	IMPELLER ASS'Y	1	PPG	φ59X59.5	1001212405
03	REAR CASING	1	PPG	φ91X59.5	1001212405
02	FRONT CASING	1	PPG	HOSE THREAD	1001412300 1011412301
01	MOTOR	1	45W,2P	100~120V 200~240V	1011212347 1001212347

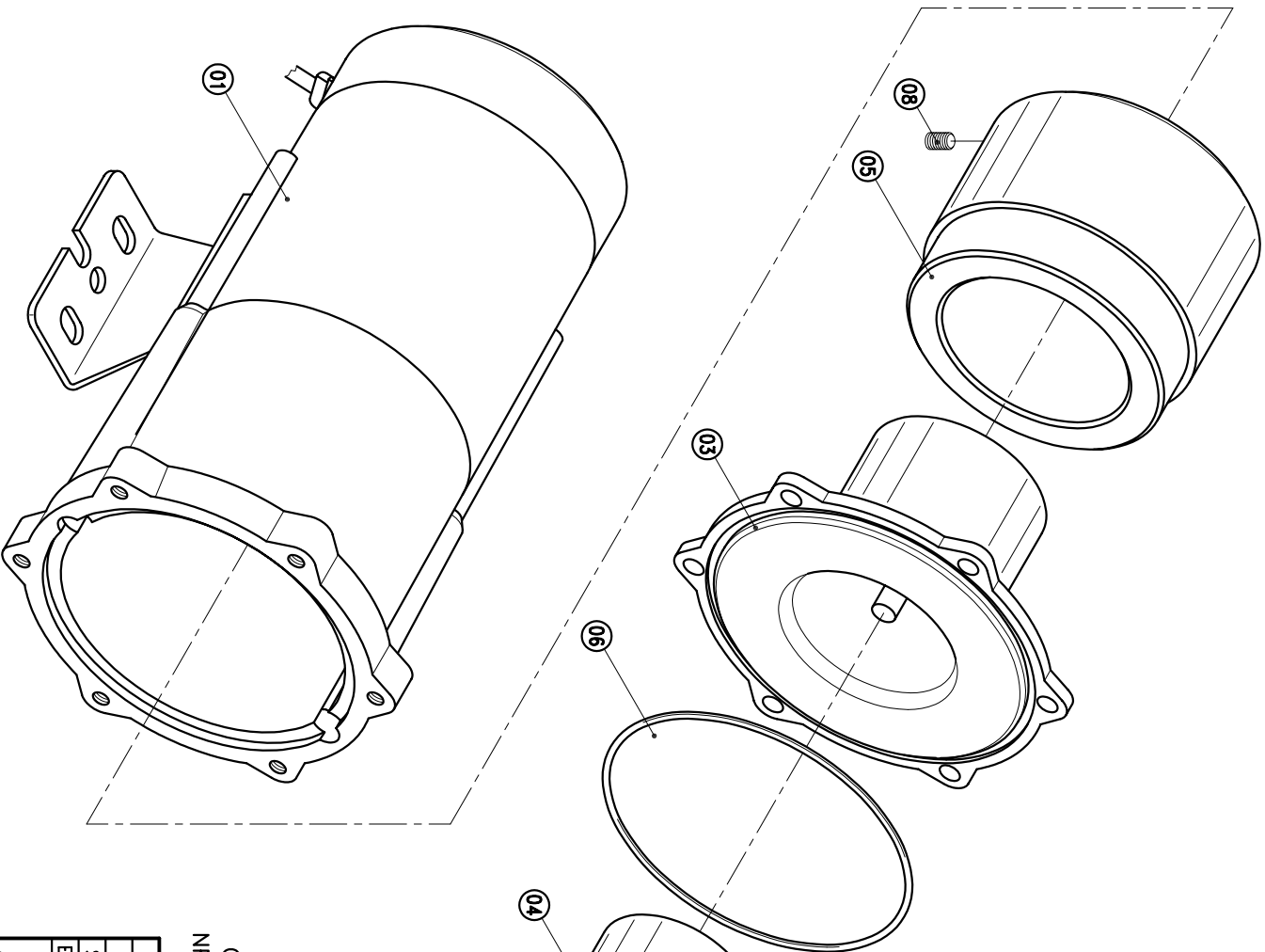

G : 3/4" X 3/4"
NPT : 3/4" X 3/4"

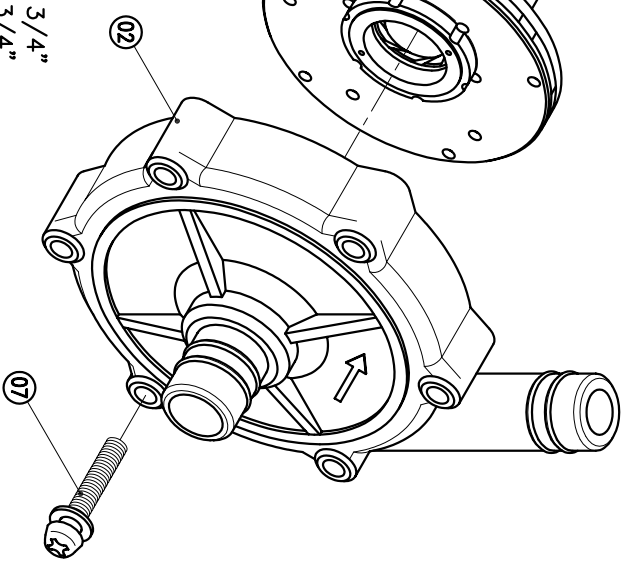

APPROVED	CHECK	DESIGN	DR.BY	MDL NAME	DWG. NAME	DWG. NO.	DECOMPOSITION	DRAWING
	07 11 02	02 27 97	07 11 02 BECKY	NH-50PX-Z		B3051207		A3

TPW
HONG YUAN

 PAN WORLD CO., LTD.
パンワールド株式会社