

09	SET SCREW	2	S435	MAX5	
08	SCREW,GROSS RECESS HEAD W/L PLAIN WASHER	4	SUS304	MAX15	
07	SCREW,GROSS RECESS HEAD W/L PLAIN WASHER	2	SUS304	MAX40	
06	O. RING	1	FKM	S67	1001512311
05	OUTER DRIVE RING	1	ADC-12	φ70X63.5	
04	IMPELLER VANE	1	PPG	φ56X59	
03	REAR CASING	1	PPG	φ80X59.5	1001212505
02-1	FRONT THRUST PAD	1	RLON	φ12X6	1001212313
02	FRONT CASING	1	PPG	HOSE THREAD	1001612310 1011612300
01	MOTOR	1	45W,2P	100~120V 200~240V	1011212367 1001212367

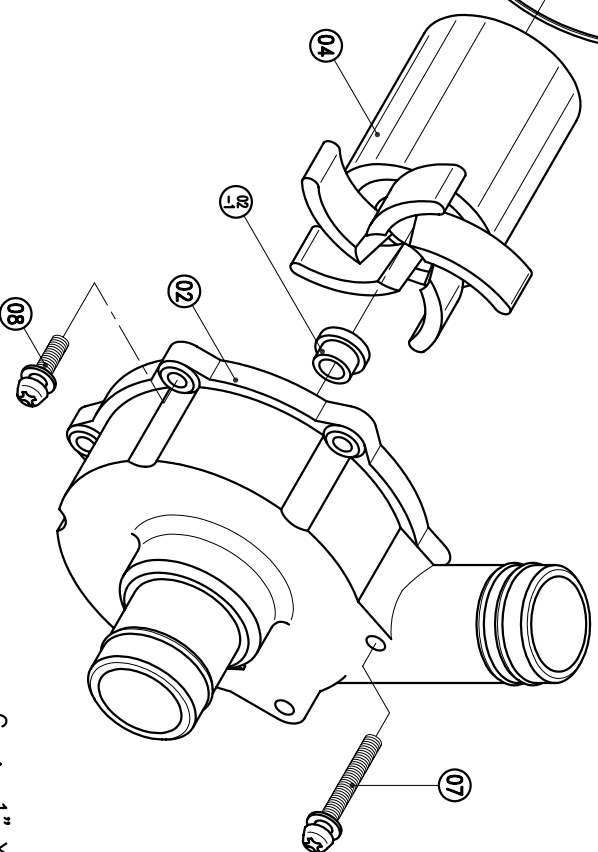
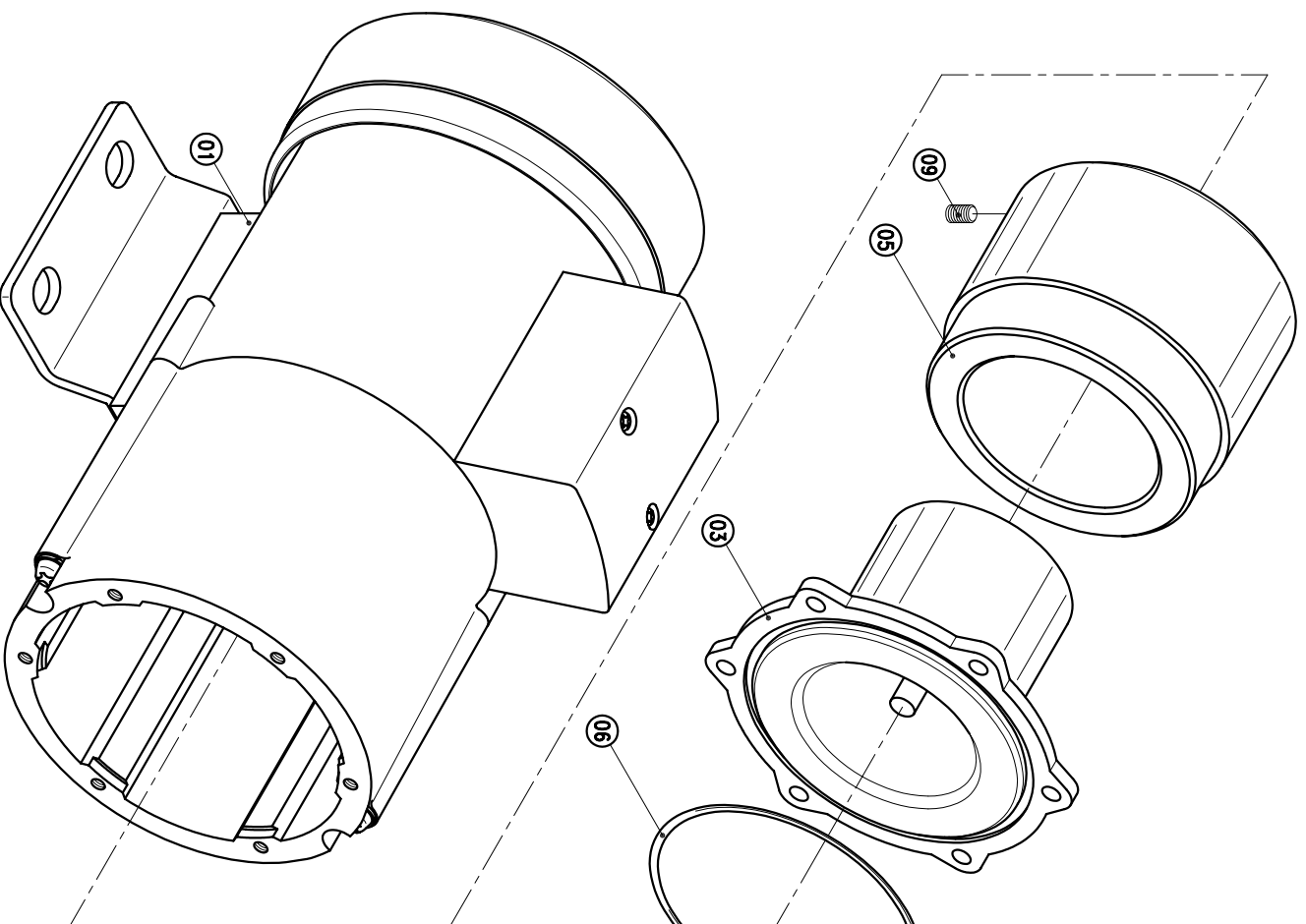

G : 1" X 1"
NPT : 1" X 1"

APPROVED	MDL NAME	NH-50PX-X
CHECK	DWG. NAME	DECOMPOSITION DRAWING
DESIGN	DWG. NO.	B3051002
DR.BY		A3
EDITION		
2		

TPW
HONG YUAN



PAN WORLD CO.,LTD.
パンワールド株式会社