

NO	PART NAME	QTY	MATERIAL	NOTE	PART NO.
08	SET SCREW	2	S435	M4X5	
07	SCREW,GROSS RECESS HEAD W/L PLAIN WASHER	6	SUS304	M4X30	
06	O. RING	1	FKM	S63	1001212311
05	OUTER DRIVE RING	1	ADC-12	φ56X54.5	1001212404
04	IMPELLER VANE	1	PPG	φ50X44	1001212305
03	REAR CASING	1	PPG	φ74X47	1011212305
02-1	FRONT THRUST PAD	1	RULON	φ10X6	1001212314
02	FRONT CASING	1	PPG	HOSE THREAD	1001312300 1011312300
01	MOTOR	1	20W,2P	100~120V 200~240V	1011212337 1001212337

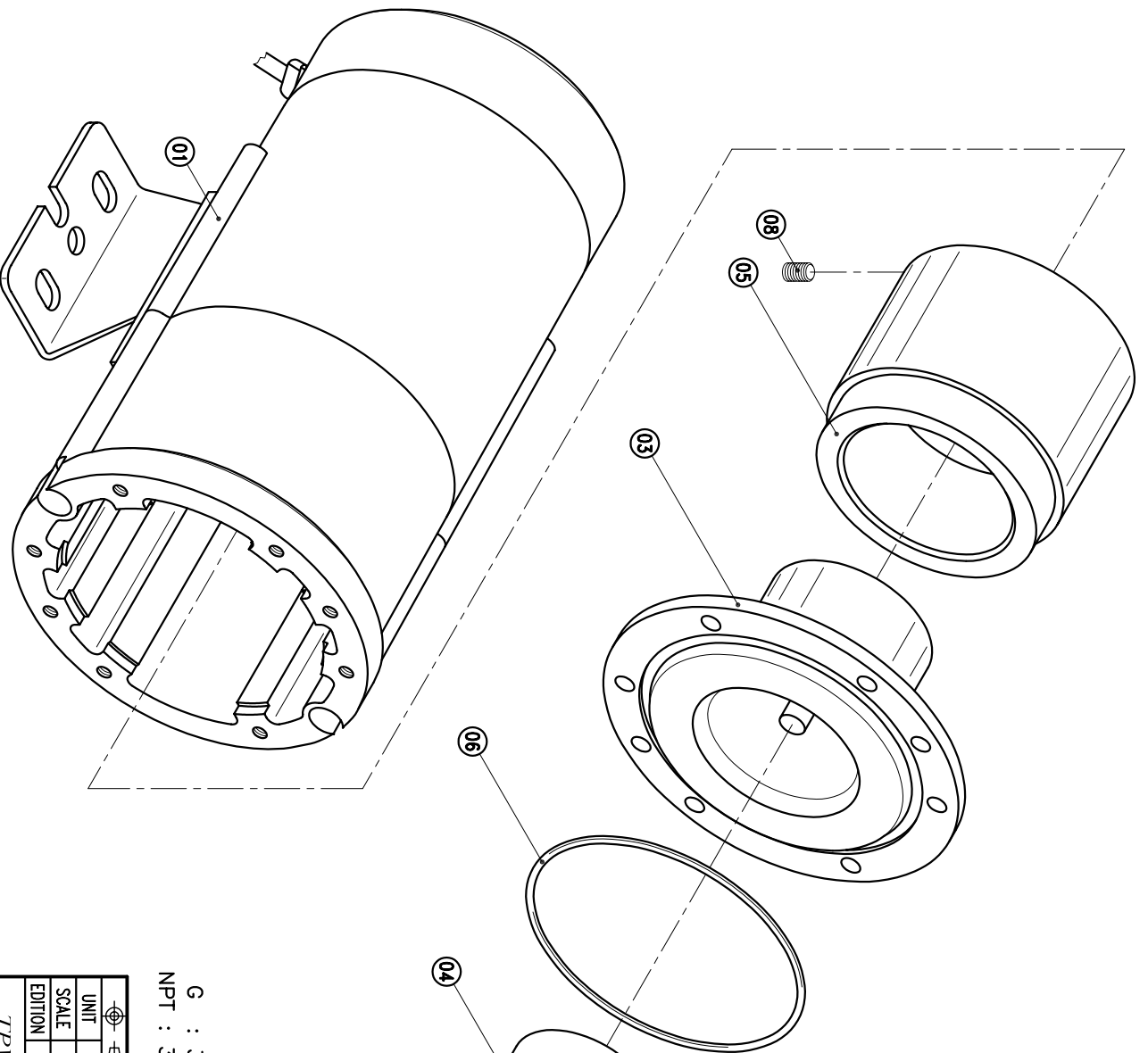

G : 3/4"X 3/4"
NPT : 3/4"X 3/4"

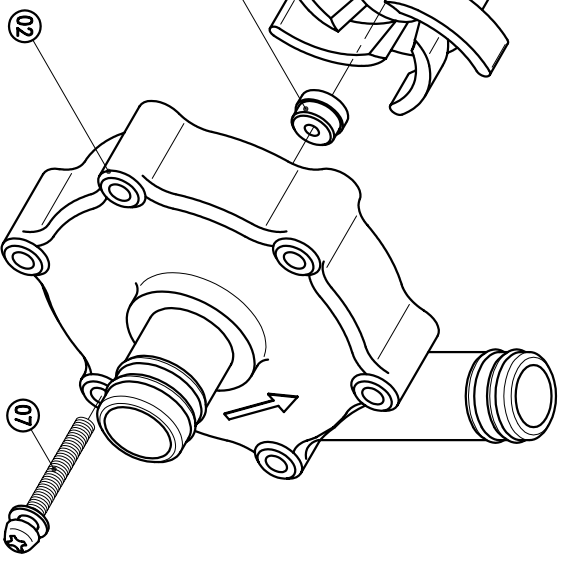

APPROVED	CHECK	DESIGN	DR.BY	MDL NAME	DWG. NAME	DECOMPOSITION	DWG. NO.	DRAWING
	07 06 02	12 31 96	07 06 02 BECKY	NH-40PX			B3041206	A3

TPW
HONG YUAN



PAN WORLD CO., LTD.
パンワールド株式会社