

07	SCREW,CROSS RECESS HEAD w/1 PLAIN WASHER	4	SUS304	M3X22	
06	O. RING	1	FKM	S45	1201112301
05	OUTER DRIVE RING	1	H14	φ41X62.5	1001112303
04	IMPELLER VANE	1	PPG	φ33X22.5	1901212305
03	REAR CASING	1	PPS	φ54X28.5	1901212305
02-1	FRONT THRUST PAD	1	RULON	φ9X1.2	1901112310
02	FRONT CASING	1	PPS	HOSE THREPAD	1901112313 1901112313
01	MOTOR	1	2.5W,2P	100~120V 200~240V	1911212307 1901212307
NO	PART NAME	Q'TY	MATERIAL	NOTE	PART NO.

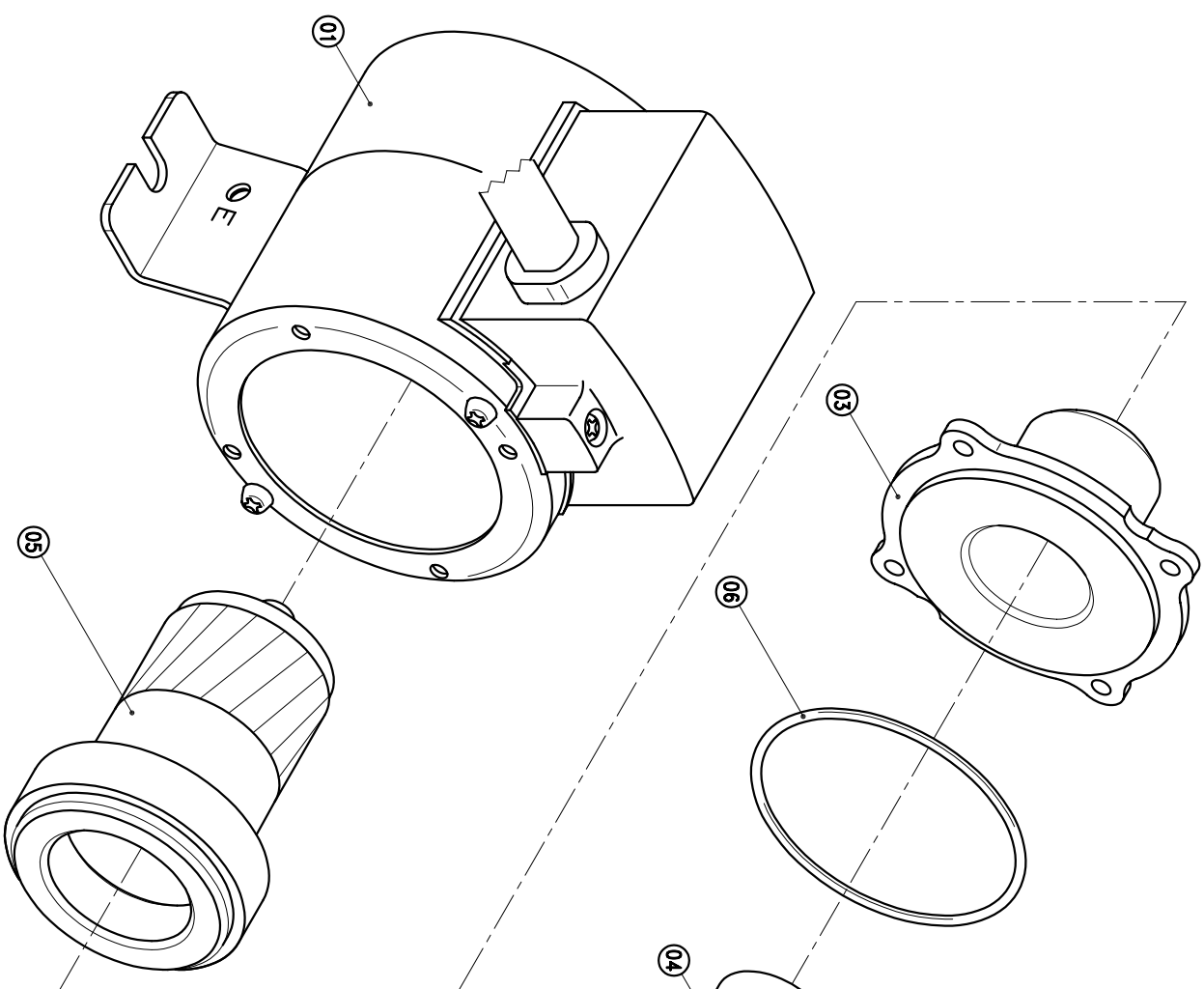

G : 1/2"X 1/2"
NPT : 1/2"X 1/2"

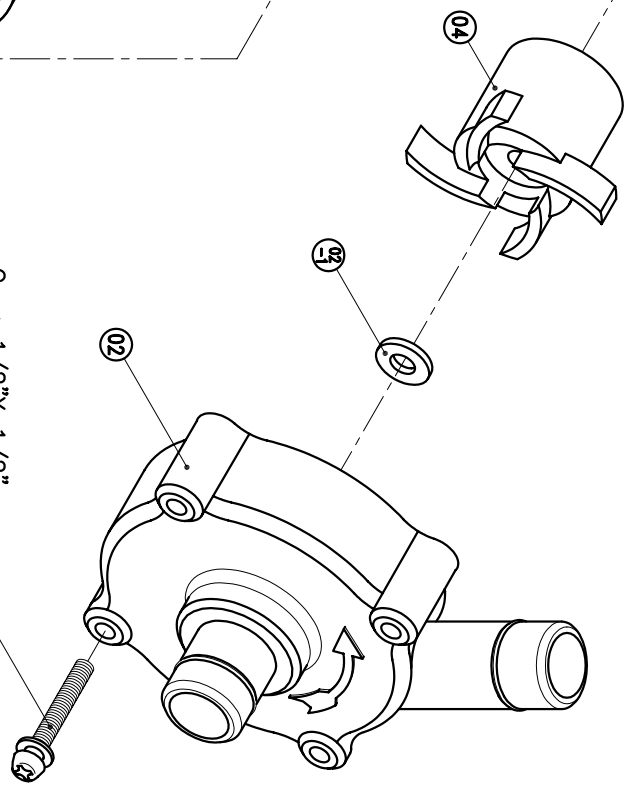

APPROVED	CHECK	12 31 03	MDL NAME	NH-1PX
SCALE	DESIGN	08 20 98	DWG. NAME	DECOMPOSITION DRAWING
EDITION	DR.BY	12 31 03 BECKY	DWG. NO.	B3001304
				A3

TPW
HONG YUAN



PAN WORLD CO., LTD.
パンワールド株式会社