

NO	PART NAME	QTY	MATERIAL	NOTE	PART NO.
08	SET SCREW	2	S435	M3X4	
07	SCREW,CROSS RECESS HEAD w/L PLAIN WASHER	4	SUS304	M4X25	
06	O. RING	1	FKM	S45	1001112311
05	OUTER DRIVE RING	1	ADC-12	φ41X26	
04	IMPELLER VANE	1	PPG	φ33X22.5	1001112303
03-1	SPINDLE	1	CERAMIC	φ4X27	1001212306
03	REAR CASING	1	PPG	φ54X20.5	1001212305
02-1	FRONT THRUST PAD	1	RULON	φ9X1.2	
02	FRONT CASING	1	PPG	HOSE THREAD	1001112310 1011112300
01	MOTOR	1	2.5W,2P	100~120V 200~240V	1011212307 1001212307

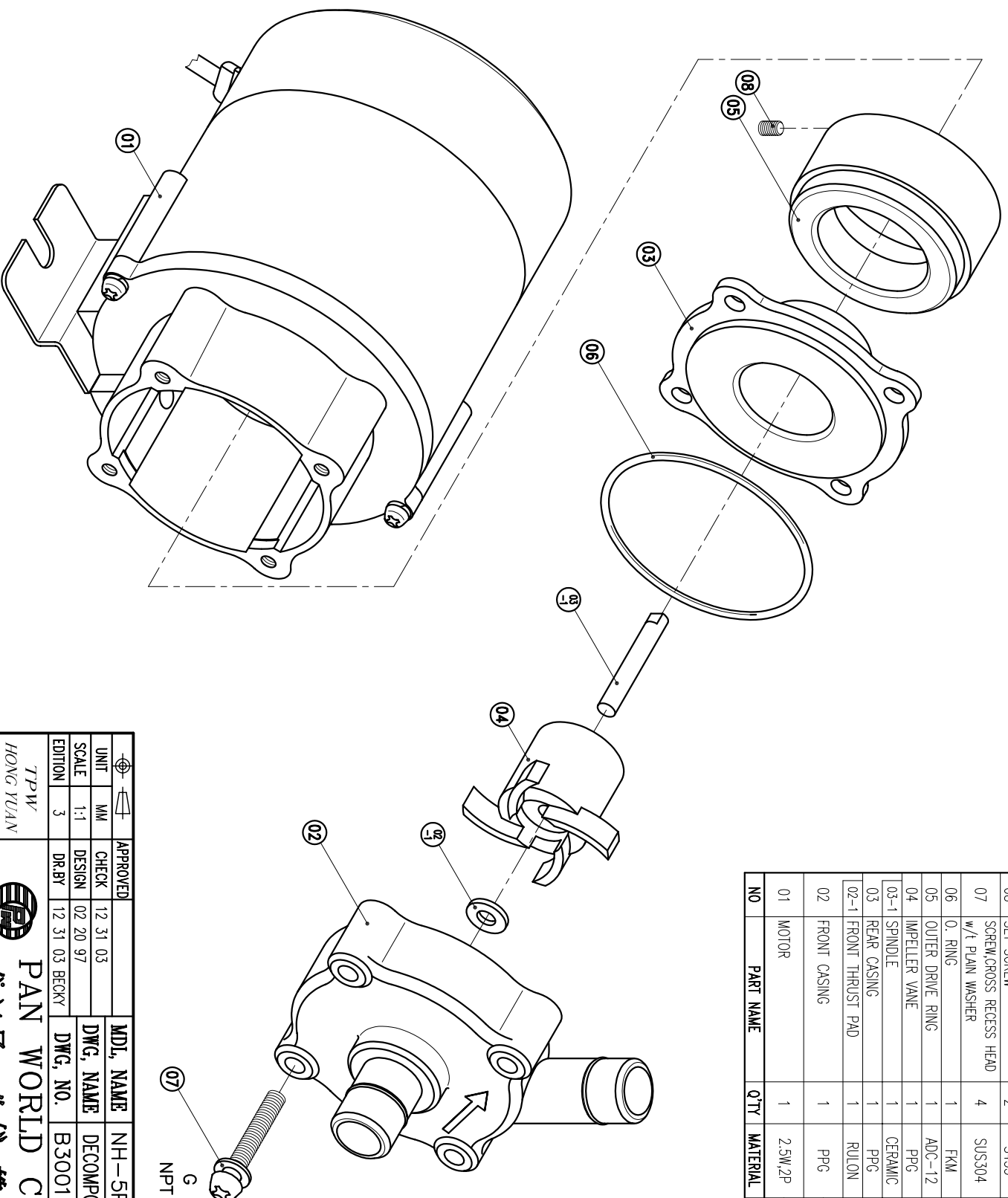

G : 1/2"X 1/2"  
NPT : 1/2"X 1/2"

APPROVED	CHECK	MDL NAME	NH-5PX
12 31 03	12 31 03	DWG. NAME	DECOMPOSITION DRAWING
02 20 97	02 20 97	DWG. NO.	B3001203
03	03	DR.BY	12 31 03 BECKY
		A3	

TPW  
HONG YUAN

 PAN WORLD CO.,LTD.  
パンワールド株式会社