

07	SCREW/CROSS RECESS HEAD w/1 PLAIN WASHER	4	SUS304	M3X22	
06	O. RING	1	FKM	S45	1201112301
05	OUTER DRIVE RING	1	ADC-12	φ41Xφ2.5	1001112305
04	IMPELLER VANE	1	PPG	φ43X22.5	1901212305
03	REAR CASING	1	PPS	φ54X28.5	1901212305
02-1	FRONT THRUST PAD	1	RULON	φ9X1.2	1901112310
02	FRONT CASING	1	PPS	HOSE THREPAD	1901112313 1901112309
01	MOTOR	1	5W.2P	100~120V 200~240V	1911212309 1911212308
NO	PART NAME	Q'TY	MATERIAL	NOTE	PART NO.

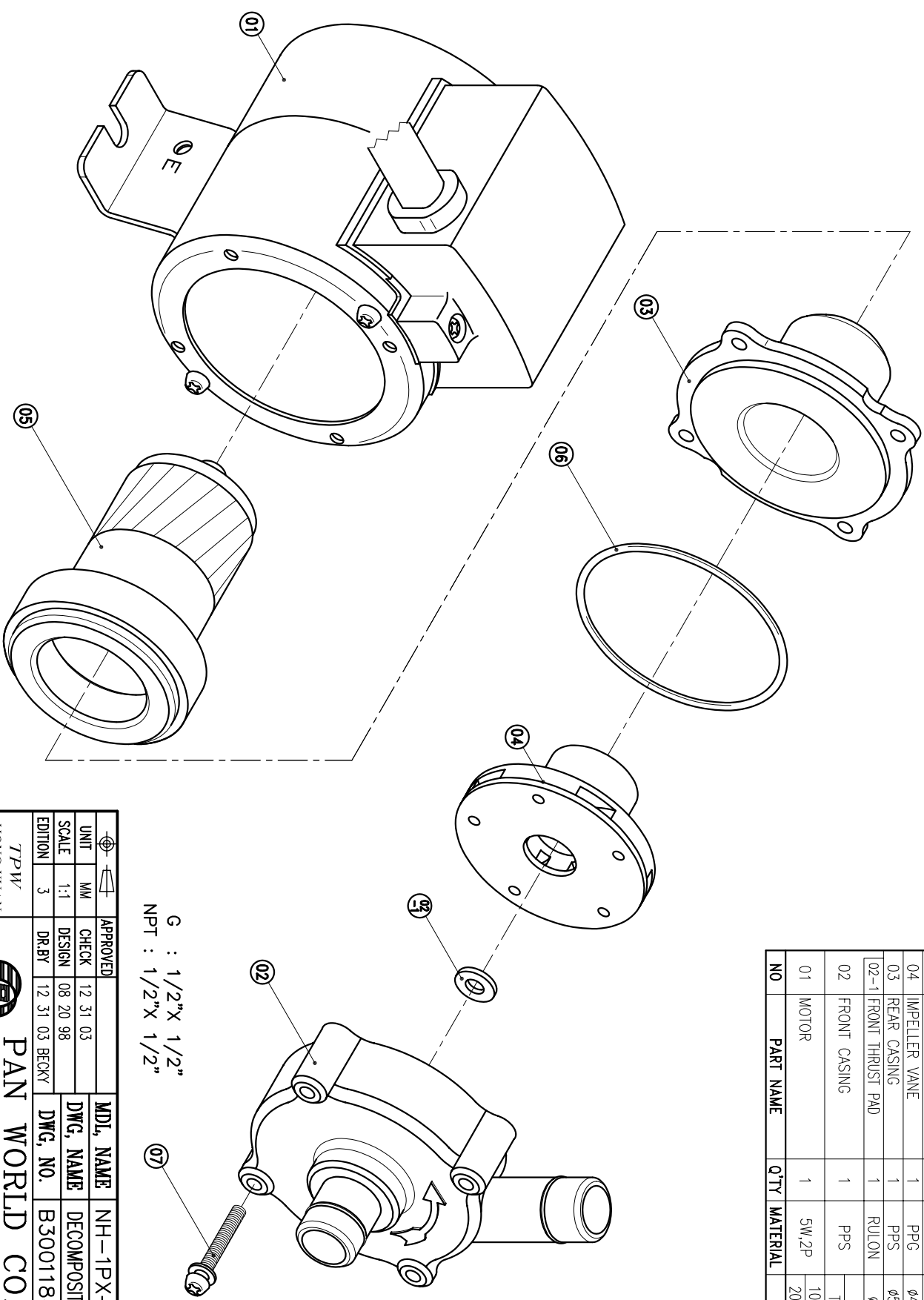

G : 1/2"X 1/2"  
NPT : 1/2"X 1/2"

APPROVED	CHECK	12 31 03	MDL NAME	NH-1PX-Z
SCALE	DESIGN	08 20 98	DWG. NAME	DECOMPOSITION DRAWING
EDITION	DR.BY	12 31 03 BECKY	DWG. NO.	B3001184
				A3

TPW  
HONG YUAN

PAN WORLD CO., LTD.  
パンワールド株式会社