

NO	PART NAME	QTY	MATERIAL	NOTE	DWG. NO.	NO	PART NAME	QTY	MATERIAL	NOTE	DWG. NO.	NO	PART NAME	QTY	MATERIAL	NOTE	DWG. NO.
03-2	SPINDLE	1	CERAMIC	φ6X50	P2339291	05-2	OUTER MAGNET	1	FERRITE	φ66X30	P2529488	09	SET SCREW	2	S435	M4X5	P9119420
03-1	REAR THRUST PAD	1	PPS	φ12Xφ6X5	P2329477	06-1	MAGNET HOUSING	1	ADC-12	φ70X48.5	P2519003	08	SCREW,GROSS RECESS HEAD W/L P.W.(φ8Xφ4.3X10.8)	4	SUS304	M4X15	A9111026
03	REAR CASING	1	PPG	φ80X59.5	P2309046	05	OUTER DRIVE RING	1	φ70X63.5	P2509196	07	SCREW,GROSS RECESS HEAD W/L P.W.(φ8Xφ4.3X10.8)	2	SUS304	M4X30	A9111026	
02-1	FRONT THRUST PAD	1	RULON	φ12Xφ6X6	P2229765	04-2	BEARING	1	φ11X31	P2469482	06	O. RING	1	FKM	φ66.5Xφ2	S67	
02	FRONT CASING	1	PPG	φ80X59.5	P2211041	04-1	INNER MAGNET	1	FERRITE	φ56Xφ17X30	P2449487	05					
01	MOTOR			100~120V,200~240V, 45W,1φ,2P		04	IMPELLER VANE	1	PPG	φ57X57.5	P2401192	06					

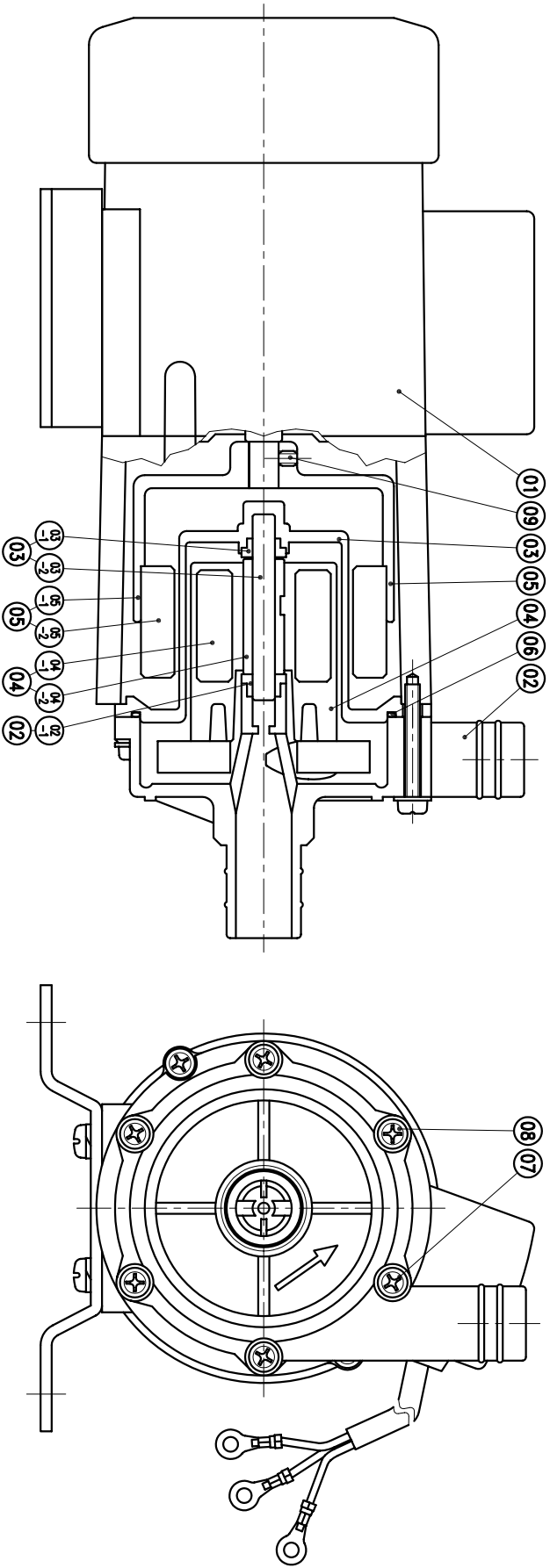

G : 3/4"X 3/4"
NPT : 3/4"X 3/4"

APPROVED	CHECK	07 16 02	MDL NAME	NH-50PX
CHECK	DESIGN	06 01 97	DWG. NAME	CONSTRUCTION DRAWING
SCALE	DR.BY	07 16 02 BECKY	DWG. NO.	B2051168
EDITION				A3

TPW
HONG YUAN



PAN WORLD CO.,LTD.
パンワールド株式会社