

NO	PART NAME	QTY	MATERIAL	NOTE	DWG. NO.	NO	PART NAME	QTY	MATERIAL	NOTE	DWG. NO.
03-2	SPINDLE	1	CERAMIC	φ6X50	P2339291	04-5	BEARING	1	CERAMIC	φ11X31	P2469482
03-1	REAR THRUST PAD	1	PPS	φ12Xφ6X5	P2329477	04-4	IMPELLER COVER	1	PPG	φ76X6	P2451044
03	REAR CASING	1	PPG	φ91X59.5	P2301047	04-3	INNER MAGNET	1	FERRITE	φ36Xφ17X30	P2449487
02-1	FRONT THRUST PAD	1	RULON	φ12Xφ6X6	P2229765	04-2	MOUTH RING	1	RULON	φ27X4.5	P2421462
02	FRONT CASING	1	PPG	φ91X48.5	P2211043	04-1	IMPELLER VANE	1	PPG	φ76X54	P2411045
01	MOTOR	100	120V, 200~240V, 45W, 1φ, 2P			04	IMPELLER ASS'Y	1	PPG	φ59X59.5	P2401195
08	SET SCREW	2	S435	M4X5	P9119420	07	SCREW, GROSS RECESS HEAD w/ L.P.W.(φ10Xφ5.3X11)	6	SUS304	M5X28	P9111136
06	O. RING	1	FKM	φ79.5X2	S80	05-2	OUTER MAGNET	1	FERRITE	φ66X30	P2529488
05-1	MAGNET HOUSING	1	ADC-12	φ70X48.5	P2519003	05	OUTER DRIVE RING	1	ADC-12	φ70X63.5	P2509196

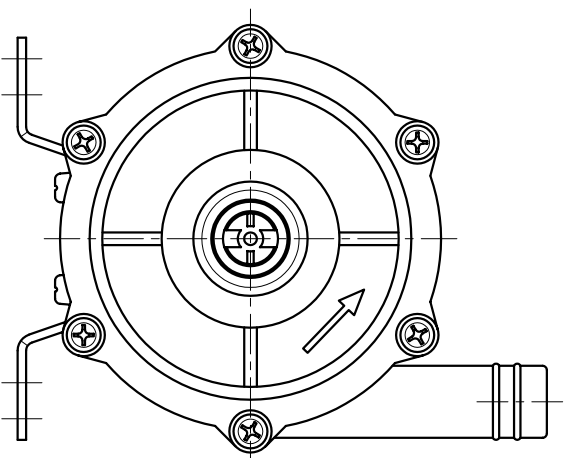
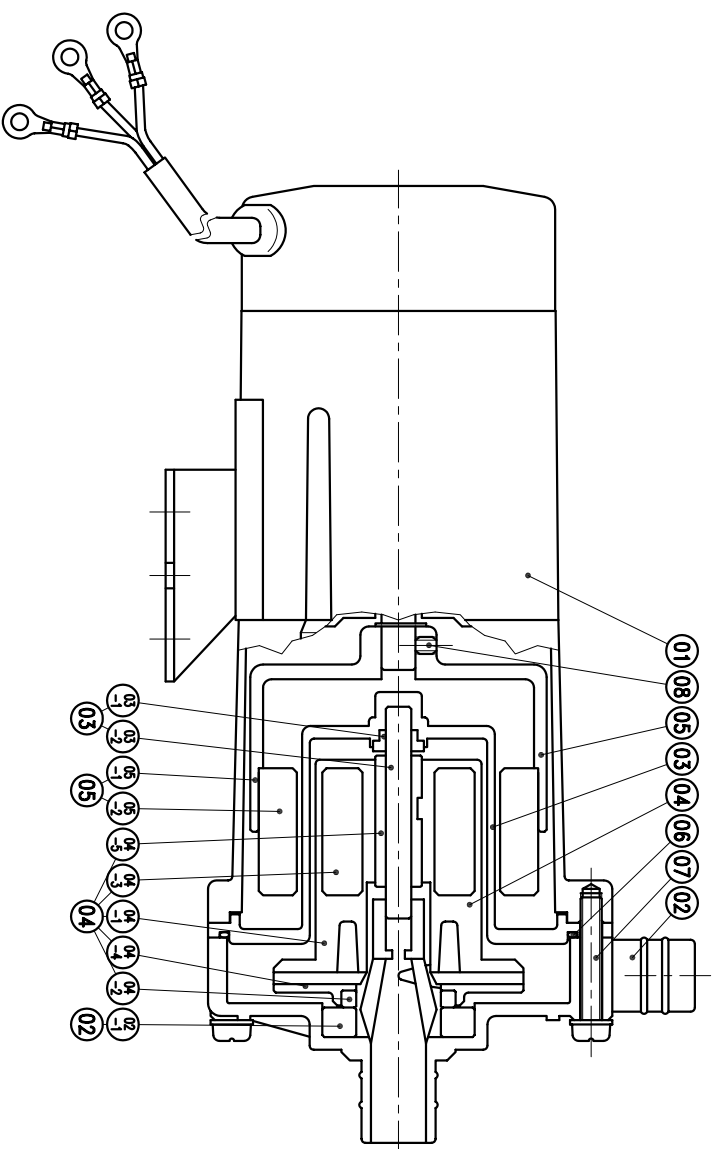

G : 3/4"X 3/4"
NPT : 3/4"X 3/4"

APPROVED	CHECK	07 11 02	MDL NAME	NH-50PX-Z
SCALE	DESIGN	06 01 97	DWG. NAME	CONSTRUCTION DRAWING
EDITION	DR.BY	07 11 02 BECKY	DWG. NO.	B2051142
				A3

TPW
HONG YUAN



PAN WORLD CO., LTD.
パンワールド株式会社