

NO	PART NAME	QTY	MATERIAL	NOTE	DWG. NO.	NO	PART NAME	QTY	MATERIAL	NOTE	DWG. NO.	NO	PART NAME	QTY	MATERIAL	NOTE	DWG. NO.
03-2	SPINDLE	1	CERAMIC	φ6X50	P2339291	05-2	OUTER MAGNET	1	FERRITE	φ66X30	P2529488	09	SET SCREW	2	S435	M4X5	P9119420
03-1	REAR THRUST PAD	1	PPS	φ12Xφ6X5	P2329477	06-1	MAGNET HOUSING	1	ADC-12	φ70X48.5	P2519003	08	SCREW,GROSS RECESS HEAD	4	SUS304	M4X15	A9111026
03	REAR CASING	1	PPG	φ80X59.5	P2309046	05	OUTER DRIVE RING	1	PPG	φ70X63.5	P2509196		W/L P.W.(φ8Xφ4.3X10.8)				
02-1	FRONT THRUST PAD	1	RULON	φ12Xφ6X6	P2229765	04-2	BEARING	1	CERAMIC	φ11X31	P2469482	07	SCREW,GROSS RECESS HEAD	2	SUS304	M4X40	A9111026
02	FRONT CASING	1	PPG	φ80X67	P2211747	04-1	INNER MAGNET	1	FERRITE	φ56Xφ17X30	P2449487		W/L P.W.(φ8Xφ4.3X10.8)				
01	MOTOR			100~120V,200~240V,45W,1φ,2P		04	IMPELLER VANE	1	PPG	φ56X59	P2409751	06	O. RING	1	FKM	φ66.5Xφ2	S67

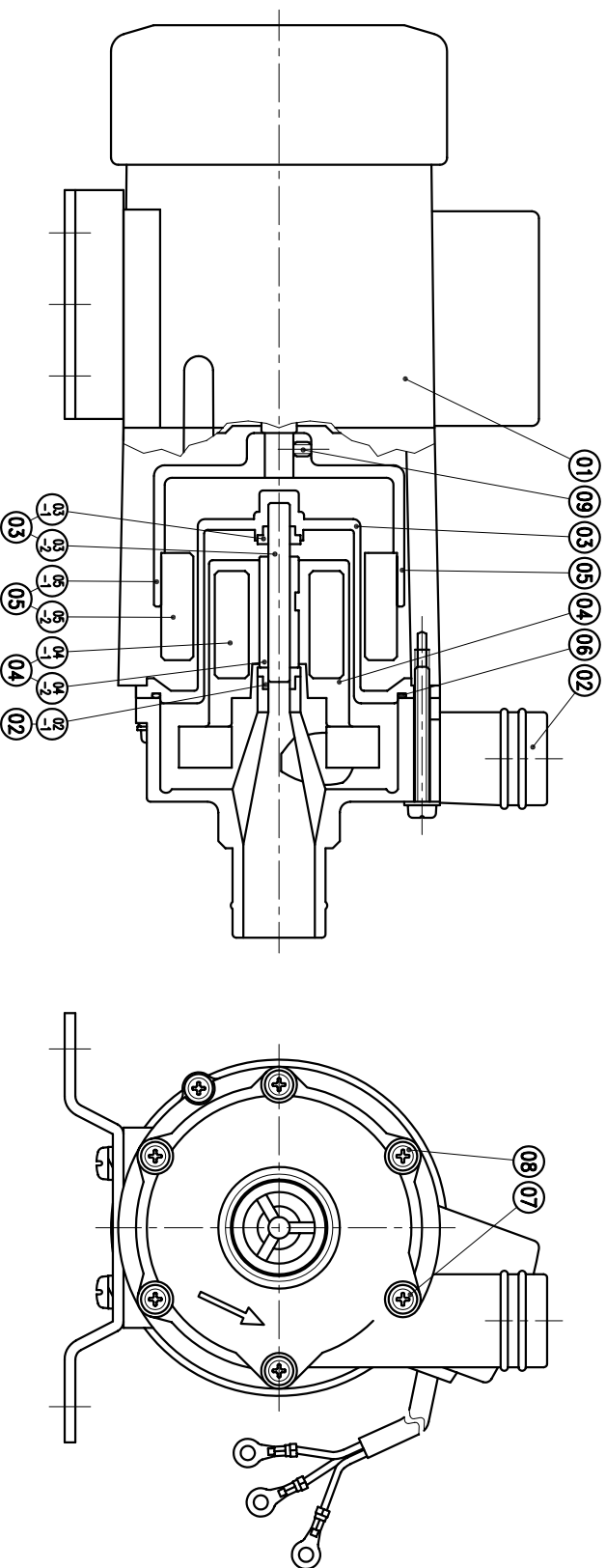

G : 1" X 1"
NPT : 1" X 1"

APPROVED	CHECK	MDL. NAME	APPROVED	CHECK	MDL. NAME
	07 16 02	NH-50PX-X		07 16 02	NH-50PX-X
	06 01 97	CONSTRUCTION DRAWING		06 01 97	CONSTRUCTION DRAWING
	07 16 02 BECKY	DWG. NO. B2051001		07 16 02 BECKY	DWG. NO. B2051001
		A3			A3

TPW
HONG YUAN



PAN WORLD CO., LTD.
パンワールド株式会社