

03	REAR CASING	1	PPS	φ54X28.5	P2301369	05	OUTER DRIVE RING	1	PPG	φ41X62.5	P2501413	07	SCREW CROSS RECESS HEAD w/t P.W.(φ6X0.2X10.5)	4	SUS304	M3X22	P9111721
02-2	SPINDLE	1	CERAMIC	φ4X29.7	P2331107	04-3	IMPELLER COVER	1	PPG	φ43X1.5	P2451123	06	O. RING	1	EKM	φ44.5Xφ2	S45
02-1	FRONT THRUST PAD	1	RULON	φ9Xφ4.2X1.2	A2221580	04-2	INNER MAGNET	1	FERRITE	φ18X12	P2441115	05-2	OUTER MAGNET	1	FERRITE	φ38Xφ25X10	P2521094
02	FRONT CASING ASS'Y	1	PPS	φ54X35	P2201370	04-1	IMPELLER VANE	1	PPG	φ43X21	P2411212	05-1	MAGNET HOUSING	1	FERRITE	φ41X59.5	P1201373
01	MOTOR	100~120V,200~240V , 5W,1φ,2P															
NO	PART NAME	Q'TY	MATERIAL	NOTE	DWG. NO.	NO	PART NAME	Q'TY	MATERIAL	NOTE	DWG. NO.	NO	PART NAME	Q'TY	MATERIAL	NOTE	DWG. NO.

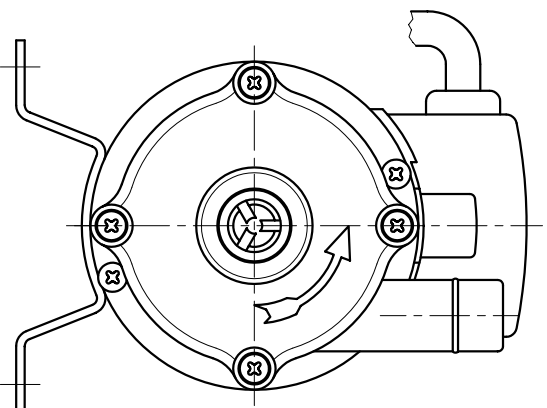
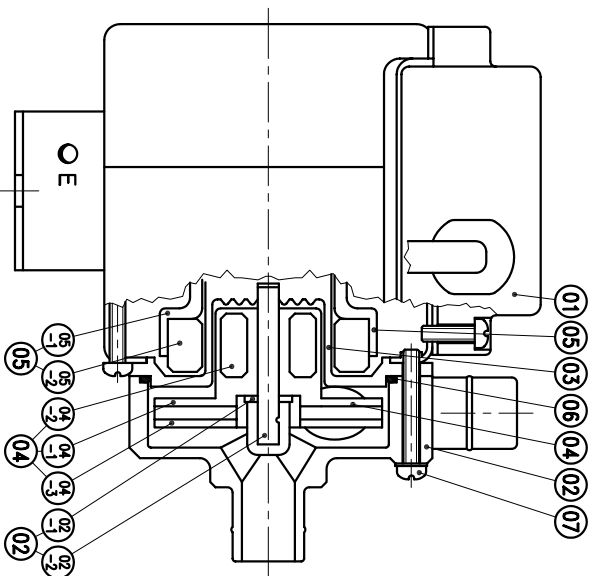

G : 1/2"X 1/2"
NPT : 1/2"X 1/2"

APPROVED		MDL. NAME	NH-1PX-Z
CHECK	12 31 03	DWG. NAME	CONSTRUCTION DRAWING
DESIGN	07 24 98	DWG. NO.	B2001305
DR.BY	12 31 03 BECKY		A3

TPW
HONG YUAN



PAN WORLD CO.,LTD.
パナワールド株式会社