

02-2	SPINDLE	1	CERAMIC	φ4X29.7	P2331107	05	OUTER DRIVE RING	1	FERRITE	φ41X62.5	P2501413	07	SCREW CROSS RECESS HEAD	4	SUS304	M3X22	P9111721
02-1	FRONT THRUST PAD	1	RULON	φ9Xφ4.2X1.2	A2221580	04-1	INNER MAGNET	1	PPG	φ18X12	P2441115	06	W/t P.W.(φ6Xφ3.2X0.5)	1	EKM	φ44.5Xφ2	S45
02	FRONT CASING ASS'Y	1	PPS	φ54X35	P2201370	04	IMPELLER VANE	1	PPG	φ33X22.5	P2401035	05-2	O. RING	1	FERRITE	φ38Xφ25X10	P2521094
01	MOTOR	100~120V,200~240V . 2.5W,φ2P				03	REAR CASING	1	PPS	φ54X28.5	P2301369	05-1	OUTER MAGNET HOUSING	1	FERRITE	φ41X59.5	P1201373
NO	PART NAME	Q'TY	MATERIAL	NOTE	DWG. NO.	NO	PART NAME	Q'TY	MATERIAL	NOTE	DWG. NO.	NO	PART NAME	Q'TY	MATERIAL	NOTE	DWG. NO.

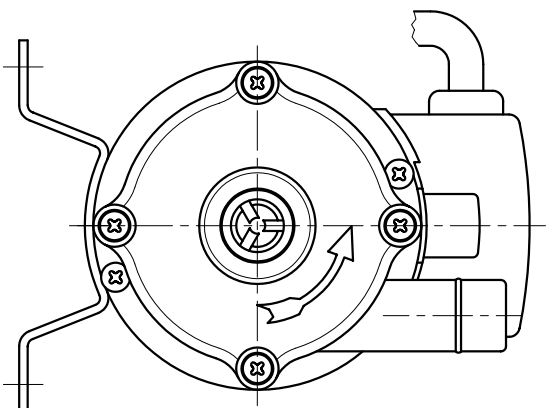
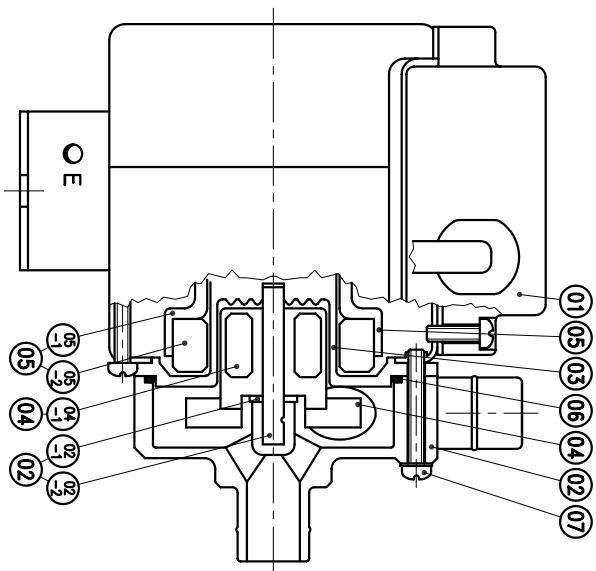

G : 1/2"X 1/2"
NPT : 1/2"X 1/2"

APPROVED	MDL. NAME	NH-1PX
CHECK	DWG. NAME	CONSTRUCTION DRAWING
DESIGN	DWG. NO.	B2001303
DR.BY		A3
12 31 03		
09 01 98		
12 31 03 BECKY		

TPW
HONG YUAN



PAN WORLD CO.,LTD.
PANワールド株式会社