

03-1	SPINDLE	1	CERAMIC	φ4X27	P2331103	05	OUTER DRIVE RING	1	φ41X26	P2501199	08	SET SCREW	2	S435	M3X4	P9111421
03	REAR CASING	1	PPG	φ54X20.5	P2301036	04-3	IMPELLER COVER	1	φ43X1.5	P2451213	07	SCREW,GROSS RECESS HEAD w/L.P.W.(φ8Xφ4.3X10.8)	4	SUS304	M4X25	A9111026
02-1	FRONT THRUST PAD	1	RULON	φ9Xφ4.2X2.5	A2221579	04-2	INNER MAGNET	1	φ18X12	P2441115	06	O. RING	1	FKM	φ44.5Xφ2	S45
02	FRONT CASING	1	PPG	φ54X38	P2201034	04-1	IMPELLER VANE	1	φ43X21	P2411212	05-2	OUTER MAGNET	1	FERRITE	φ38Xφ25X10	P2521094
01	MOTOR			100~120V,200~240V, 5W,1φ,2P		04	IMPELLER ASS'Y	1	φ43X22.5	P2401211	05-1	MAGNET HOUSING	1	ADC-12	φ41Xφ5X21	P2511004

NO	PART NAME	QTY	MATERIAL	NOTE	DWG. NO.
08	SET SCREW	2	S435	M3X4	P9111421
07	SCREW,GROSS RECESS HEAD w/L.P.W.(φ8Xφ4.3X10.8)	4	SUS304	M4X25	A9111026
06	O. RING	1	FKM	φ44.5Xφ2	S45
05-2	OUTER MAGNET	1	FERRITE	φ38Xφ25X10	P2521094
05-1	MAGNET HOUSING	1	ADC-12	φ41Xφ5X21	P2511004

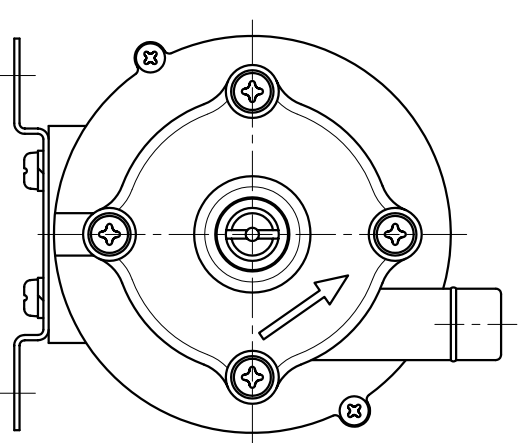
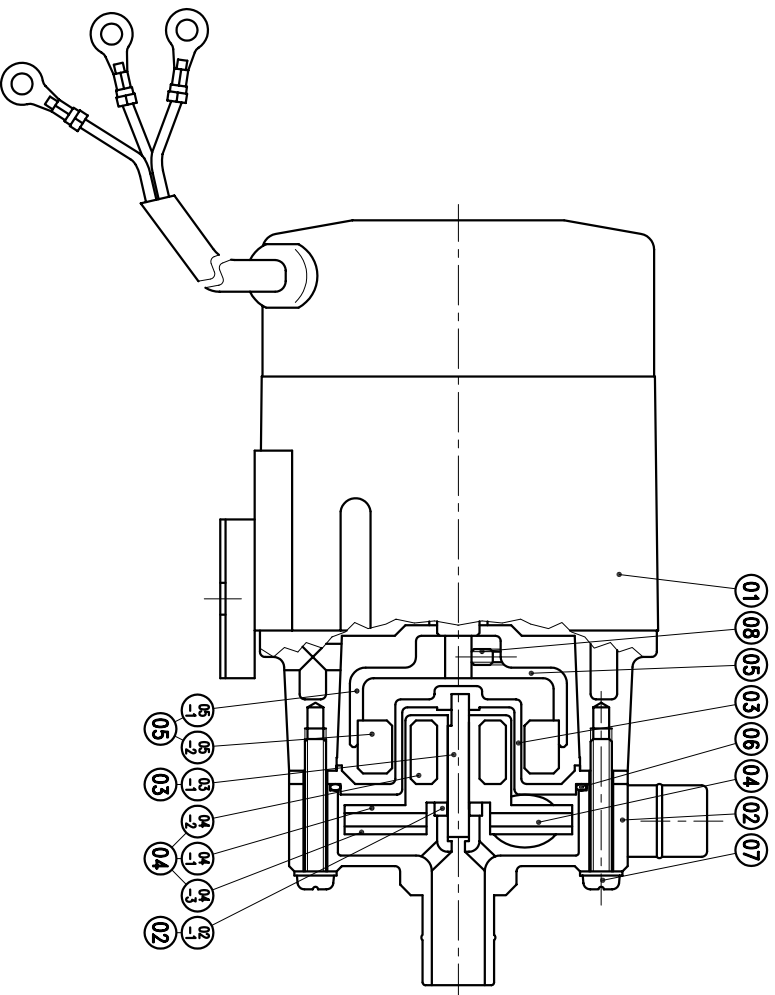

G : 1/2"X 1/2"  
NPT : 1/2"X 1/2"

APPROVED	CHECK	12 31 03	MDL NAME	NH-5PX-Z
SCALE	DESIGN	03 24 97	DWG. NAME	CONSTRUCTION DRAWING
EDITION	DR.BY	12 31 03 BECKY	DWG. NO.	B2001214
				A3

TPW  
HONG YUAN



PAN WORLD CO.,LTD.  
パンワールド株式会社