

NO	PART NAME	Q'TY	MATERIAL	NOTE	PART NO.
09	SET SCREW	2	S435	MAX5	
08	SCREW,GROSS RECESS HEAD W/L PLAIN WASHER	4	SUS304	MAX15	
07	SCREW,GROSS RECESS HEAD W/L PLAIN WASHER	2	SUS304	MAX40	
06	O. RING	1	FKM	S67	1201412301
05	OUTER DRIVE RING	1	ADC-12	Ø70X63.5	
04	IMPELLER VANE	1	PVDF	CERAMIC	
03	REAR CASING	1	PVDF	SIC	1441212505
02-1	FRONT THRUST PAD	1	SIC	Ø10X6	1201212302
		1	RULON	Ø12X6	1001212313
02	FRONT CASING	1	PVDF	HOSE THREAD	
01	MOTOR	1	65W-2P	100~120V 200~240V	1011212387 1001212387

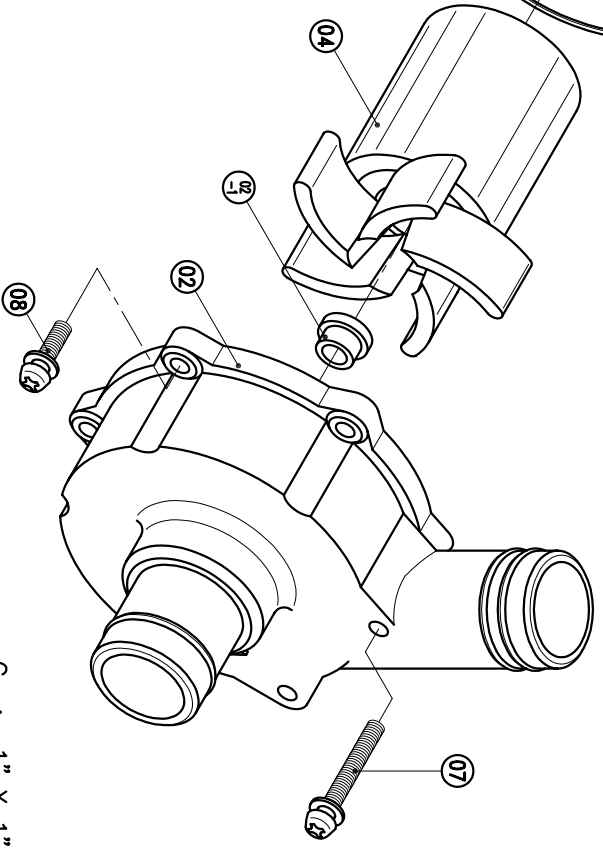
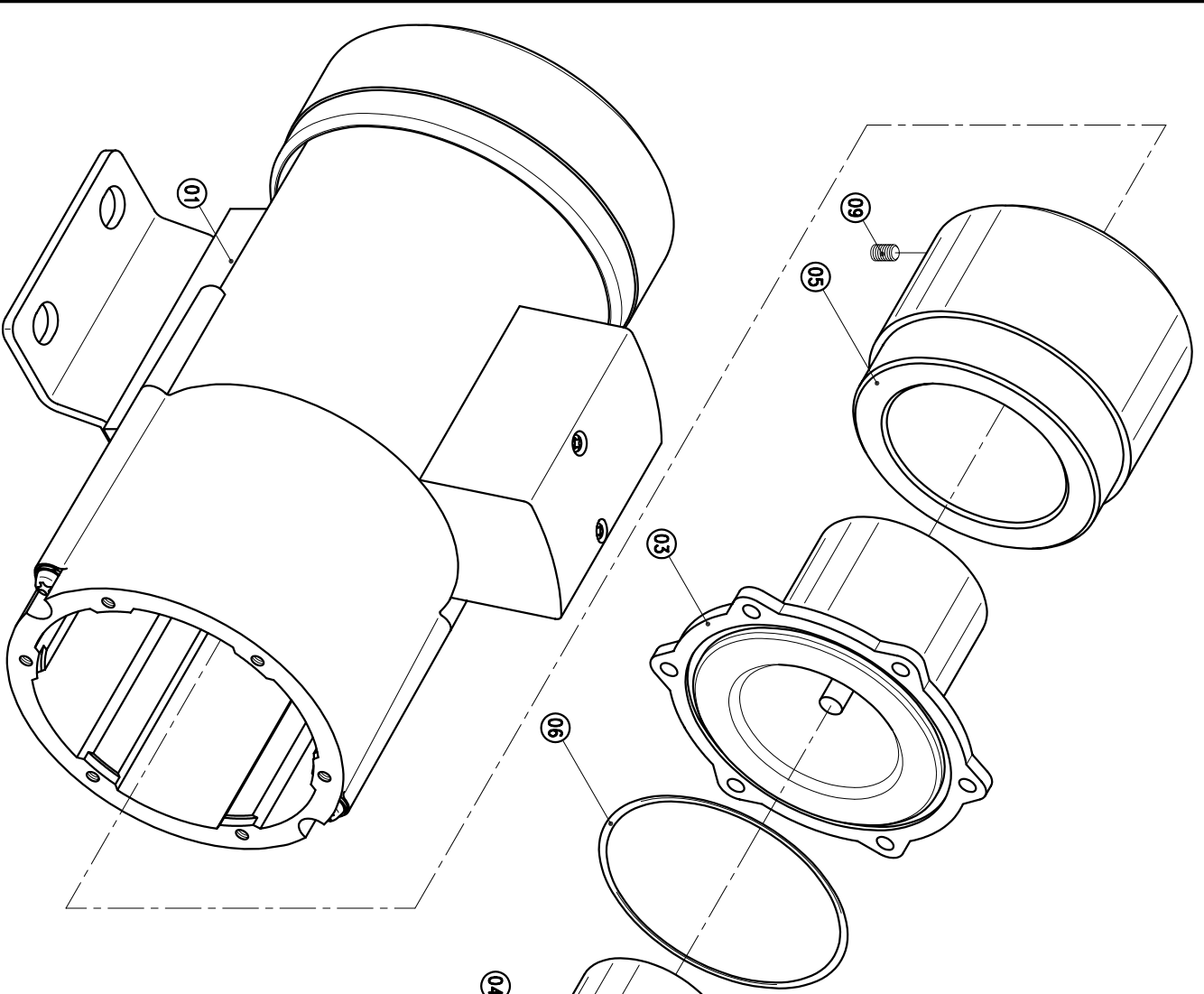

G : 1" X 1"
NPT : 1" X 1"

APPROVED	CHECK	MDL NAME	DECOMPOSITION DRAWING
07 16 02	07 16 02	NH-100PX-X-N	
DESIGN	DESIGN	DWG. NAME	DWG. NO.
03 03 97	03 03 97		B3101122
DR.BY	DR.BY		A3
07 16 02 BECKY	07 16 02 BECKY		

TPW
HONG YUAN



PAN WORLD CO.,LTD.
パンワールド株式会社