

08	SET SCREW	2	S435	MAX5	
07	SCREW,GROSS RECESS HEAD W/L PLAIN WASHER	6	SUS304	MAX30	
06	O. RING	1	FKM	S63	1201212301
05	OUTER DRIVE RING	1	ADC-12	φ56X54.5	
04	IMPELLER VANE	1	PVDF	SIC	1201212404
03	REAR CASING	1	PVDF	CERAMIC	1201213404
				SIC	1211212305
				CERAMIC	1211212307
02-1	FRONT THRUST PAD	1	RULON	φ10X6	1201212303
02	FRONT CASING	1	PVDF	HOSE 1201312300	1201212314
				THREAD 100~120V	1211312300
01	MOTOR	1	20W,2P	200~240V	1011212337
					1001212337

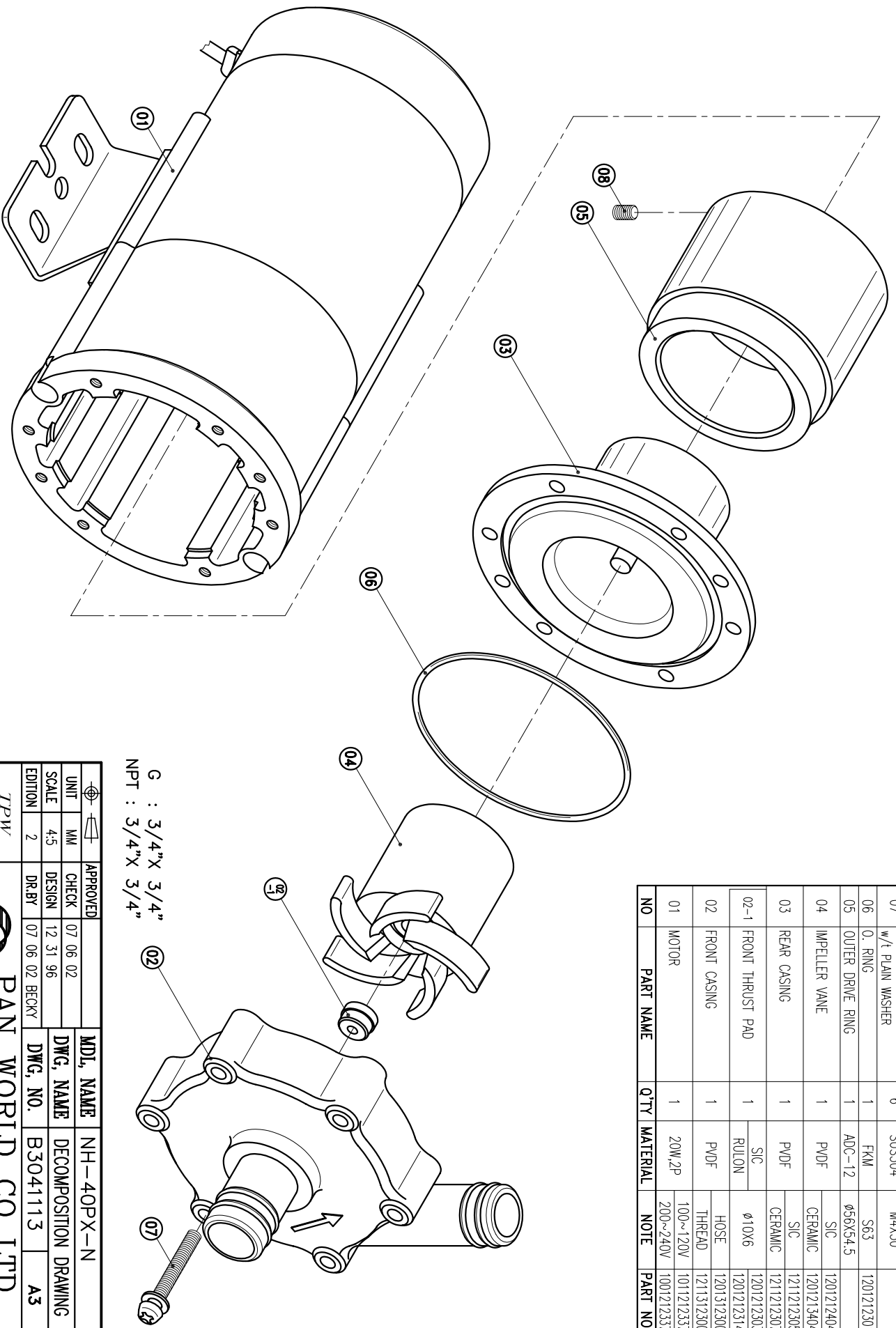

G : 3/4" X 3/4"  
NPT : 3/4" X 3/4"

APPROVED	CHECK	07 06 02	MDL NAME	NH-40PX-N
SCALE	DESIGN	12 31 96	DWG. NAME	DECOMPOSITION DRAWING
EDITION	DR.BY	07 06 02 BECKY	DWG. NO.	B3041113
				A3

TPW  
HONG YUAN



PAN WORLD CO., LTD.  
パンワールド株式会社