

07	SCREW,GROSS RECESS HEAD w/ PLAIN WASHER	4	SUS304	M3X22	
06	O. RING	1	FKM	S45	1201112301
05	OUTER DRIVE RING	1	ADC-12	φ41X62.5	
04	IMPELLER VANE	1	PP	φ40X22.5	1901212328
03	REAR CASING	1	PVDF	φ54X28.5	1901212329
02-1	FRONT THRUST PAD	1	RULON	φ9X1.2	
			SIC	HOSE	1901212324
02	FRONT CASING	1	CERAMIC	THREAD	
			HOSE	HOSE	
01	MOTOR	1	5W,2P	THREAD	1901212325
				100~120V	1911212309
				200~240V	1911212308

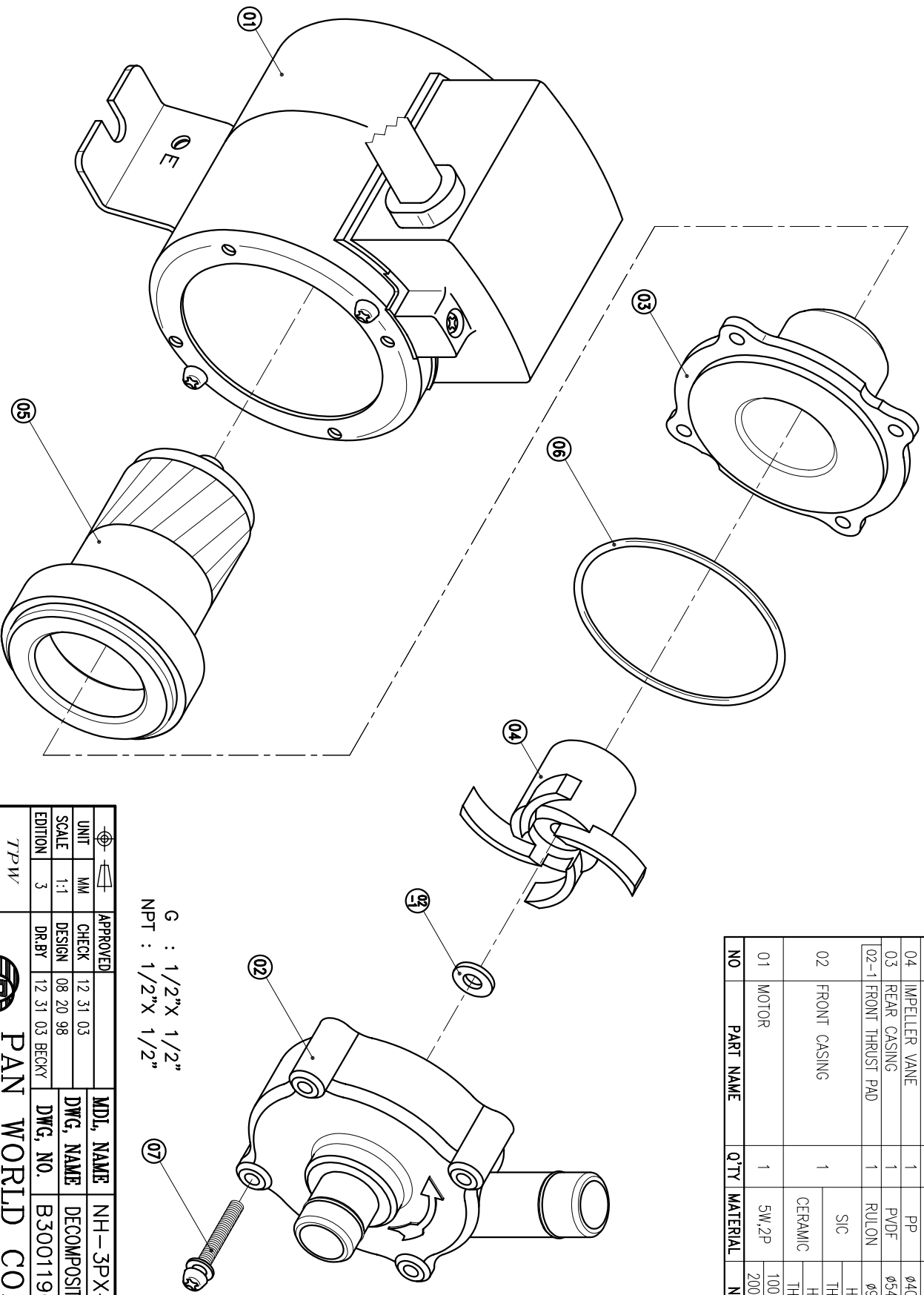

G : 1/2"X 1/2"
NPT : 1/2"X 1/2"

APPROVED	CHECK	MDL. NAME	NH-3PX-N
12 31 03	08 20 98	DWG. NAME	DECOMPOSITION DRAWING
1:1	DESIGN	DWG. NO.	B3001190
3	DR.BY		A3
	12 31 03 BECKY		

TPW
HONG YUAN



PAN WORLD CO.,LTD.
パンワールド株式会社