

07	SCREW,GROSS RECESS HEAD w/1 PLAIN WASHER	4	SUS304	M3X22	
06	O. RING	1	FKM	S45	1201112301
05	OUTER DRIVE RING	1	ADC-12	φ41X62.5	
04	IMPELLER VANE	1	PP	φ33X22.5	1901212326
03	REAR CASING	1	PVDF	φ54X28.5	1901212329
02-1	FRONT THRUST PAD	1	RULON	φ9X1.2	
			SIC	HOSE	1901212324
02	FRONT CASING	1	CERAMIC	THREAD HOSE	
01	MOTOR	1	2.5W,2P	100~120V 200~240V	1901212325 1911212307 1901212307
NO	PART NAME	Q'TY	MATERIAL	NOTE	PART NO.

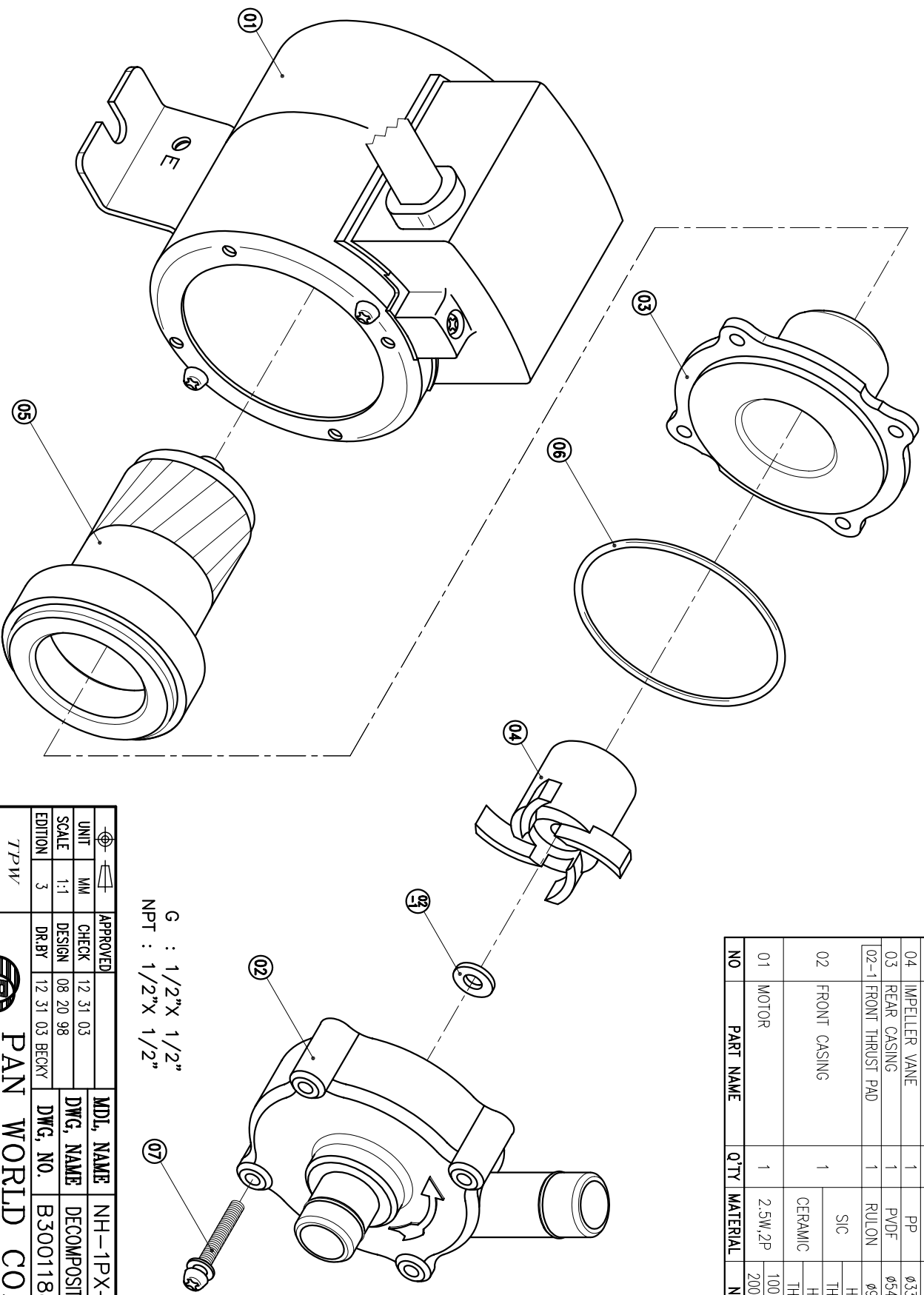

G : 1/2"X 1/2"
NPT : 1/2"X 1/2"

APPROVED	CHECK	MDL. NAME	NH-1PX-N
12 31 03	08 20 98	DWG. NAME	DECOMPOSITION DRAWING
1:1	DESIGN	DWG. NO.	B3001188
3	DR.BY 12 31 03 BECKY		A3

TPW
HONG YUAN



PAN WORLD CO.,LTD.
パンワールド株式会社