

NO	PART NAME	QTY	MATERIAL	NOTE	PART NO.
08	SET SCREW	2	S435	M3X4	
07	SCREW,CROSS RECESS HEAD w/L PLAIN WASHER	4	SUS304	M4X25	
06	O. RING	1	FKM	S45	1201112301
05	OUTER DRIVE RING	1	ADC-12	φ41X26	1201212306
04	IMPELLER VANE	1	PPG	φ33X22.5	1001112303
03-1	SPINDLE	1	SIC	φ4X27	1201212306
			CERAMIC		1001212306
03	REAR CASING	1	PVDF	φ54X20.5	1001212305
02-1	FRONT THRUST PAD	1	RULON	φ9X1.2	1001112300
02	FRONT CASING	1	PVDF	HOSE THREAD	1011112300 1011212307
01	MOTOR	1	2.5W,2P	100~120V 200~240V	1001212307 1001212307

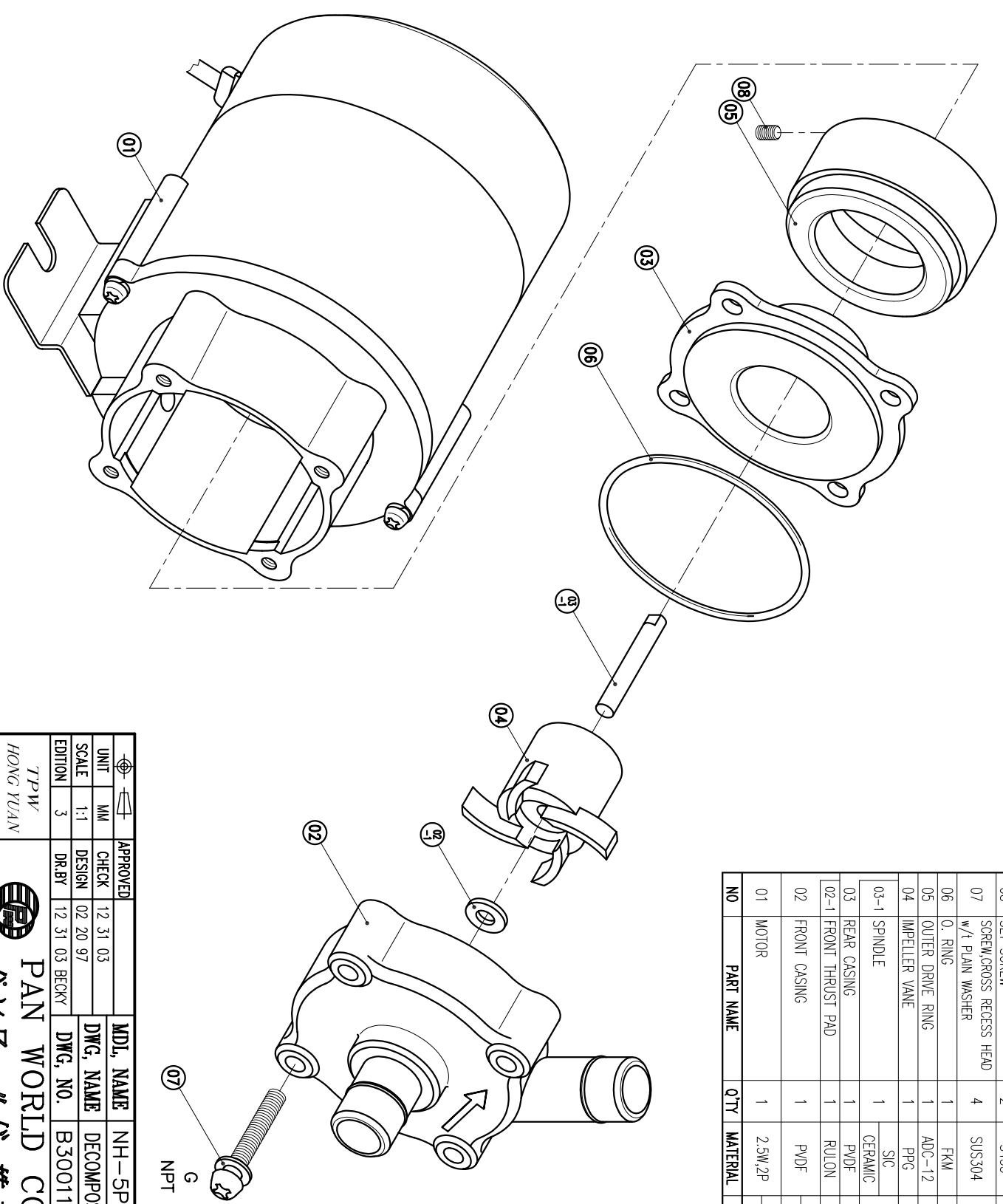

G : 1/2"X 1/2"
NPT : 1/2"X 1/2"

APPROVED	CHECK	MDL. NAME	NH-5PX-N
12 31 03	12 31 03	DWG. NAME	DECOMPOSITION DRAWING
02 20 97	02 20 97	DWG. NO.	B3001109
03	03	DR.BY	12 31 03 BECKY
3		A3	

TPW
HONG YUAN



PAN WORLD CO., LTD.
パンワールド株式会社