

NO	PART NAME	Q'TY	MATERIAL	NOTE	PART NO.
08	SET SCREW	2	S435	M4X5	
07	SCREW,GROSS RECESS HEAD W/L PLAIN WASHER	6	SUS304	M5X28	
06	O. RING	1	FKM	S80	1201412301
05	OUTER DRIVE RING	1	ADC-12	φ70X63.5	
04	IMPELLER ASS'Y	1	PVDF	SIC	1201212504
				SIC	1201213504
03	REAR CASING	1	PVDF	CERAMIC	1211212308
				CERAMIC	1211212308
02	FRONT CASING	1	PVDF	HOSE	1201412300
				SIC	1201412300
01	MOTOR	1	BRUSH LESS	HOSE	1211412300
				DC 12 V	
				DC 24 V	1301212347

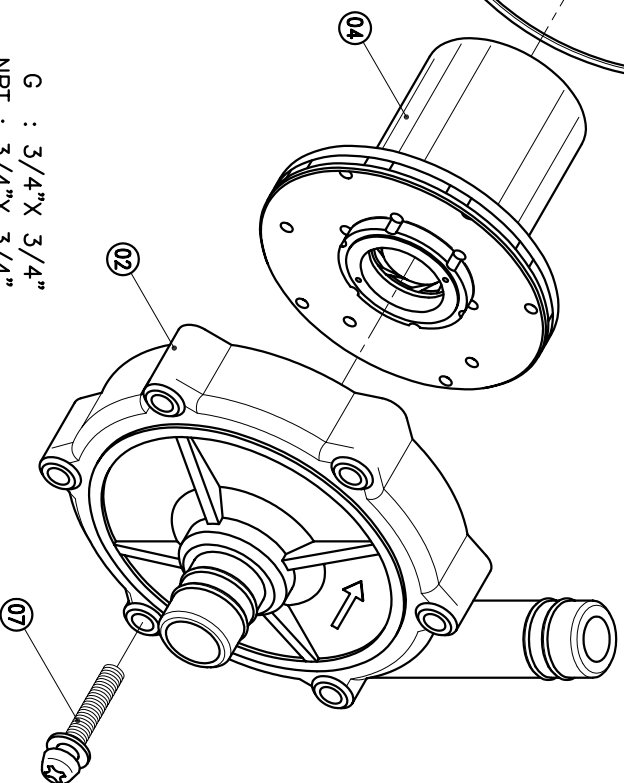
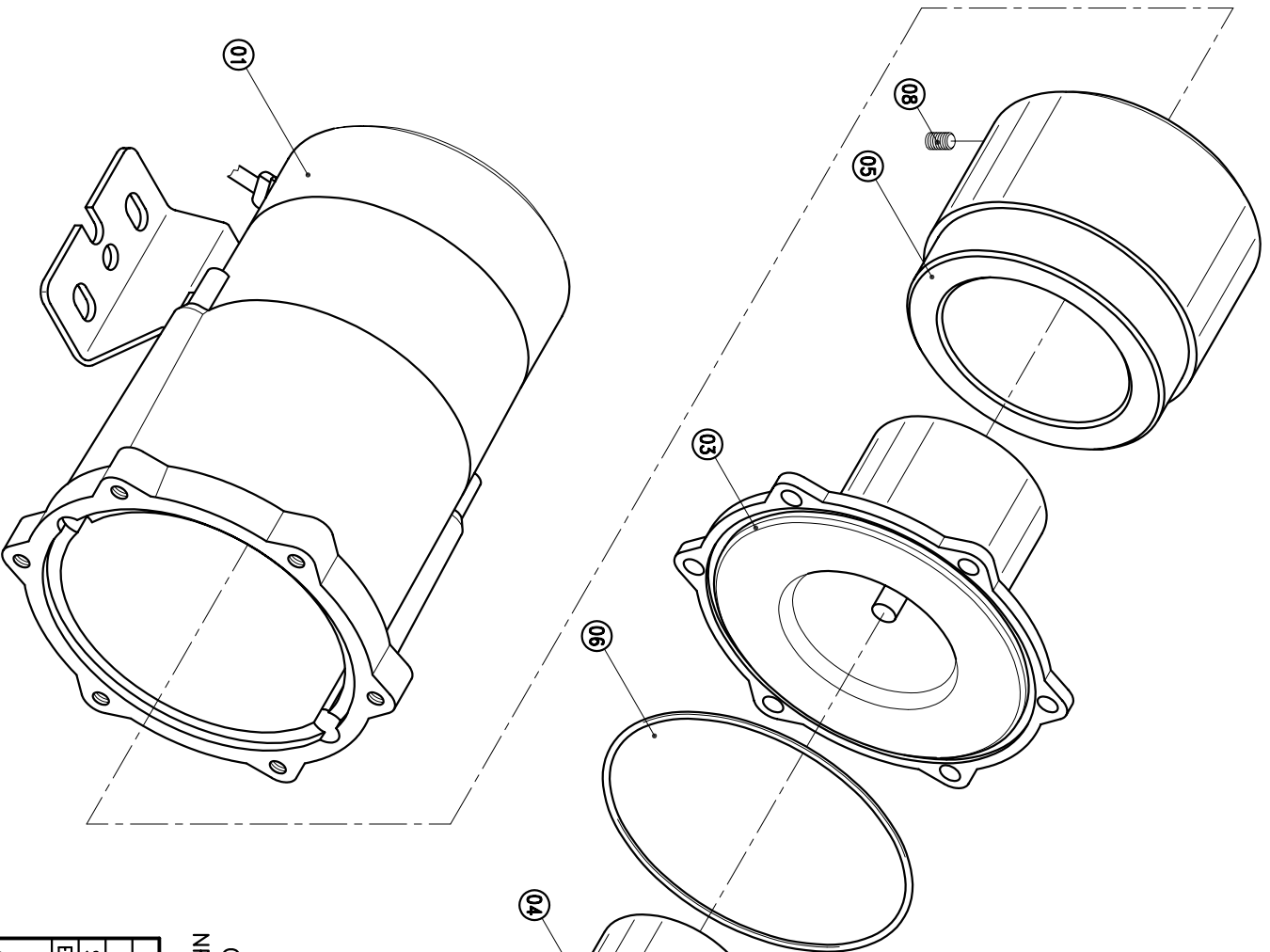

G : 3/4" X 3/4"
NPT : 3/4" X 3/4"

APPROVED	CHECK	MDL NAME	UNIT
08 02 02	08 02 02	NH-50PX-Z-D-N	MM
DESIGN	02 27 97	DECOMPOSITION DRAWING	SCALE 7:10
DR.BY	08 02 02 BECKY	DWG. NO. B3051561	EDITION 2

TPW
HONG YUAN



PAN WORLD CO., LTD.
パンワールド株式会社

A3