

NO	PART NAME	Q'TY	MATERIAL	NOTE	PART NO.
08	SET SCREW	2	S435	MAX5	
07	SCREW,GROSS RECESS HEAD W/L PLAIN WASHER	4	SUS304	MAX15	
06	O. RING	1	FKM	S63	1201212301
05	OUTER DRIVE RING	1	ADC-12	φ56X54.5	
04	IMPELLER VANE	1	PVDF	SIC	1201212304
03	REAR CASING	1	PVDF	SIC	1211212305
				CERAMIC	1211212307
02-1	FRONT THRUST PAD	1	RULON	φ10X5	1201212302
02	FRONT CASING	1	PVDF	HOSE THREAD	1201212300 1211212300
01	MOTOR	1	BRUSH LESS 17 W	DC 12 V DC 24 V	1301212327

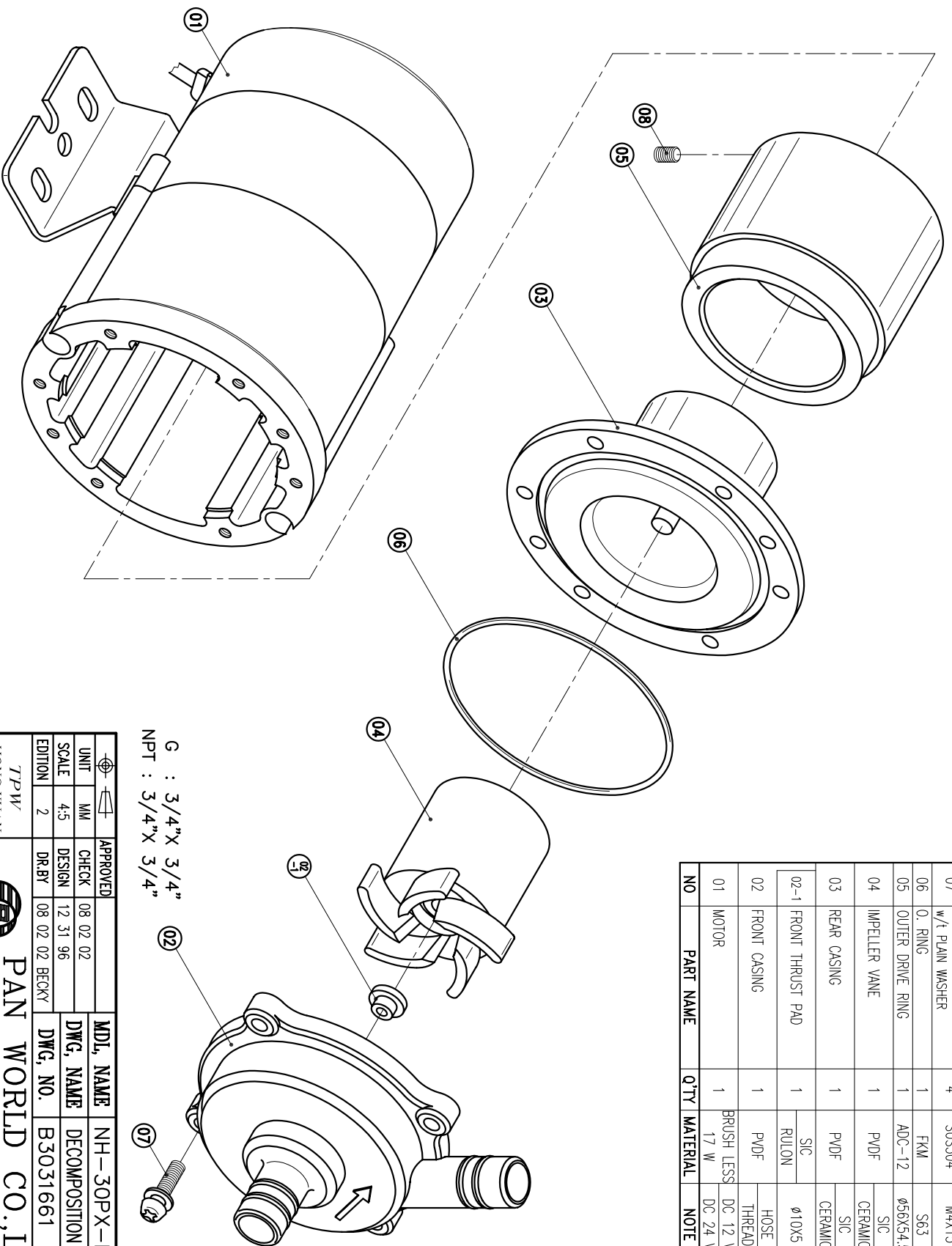

G : 3/4" X 3/4"
NPT : 3/4" X 3/4"

APPROVED	CHECK	DESIGN	DR.BY	MDL NAME	DWG. NAME	DWG. NO.	A3
	08 02 02	12 31 96	08 02 02 BECKY	NH-30PX-D-N	DECOMPOSITION DRAWING	B3031661	
UNIT	MM	SCALE	4:5	EDITION	2		

TPW
HONG YUAN



PAN WORLD CO., LTD.
パンワールド株式会社