

NO	PART NAME	QTY	MATERIAL	NOTE	PART NO.
08	SET SCREW	2	S435	M3X4	
07	SCREW,CROSS RECESS HEAD w/L PLAIN WASHER	4	SUS304	M4X25	
06	O. RING	1	FKM	S45	1001112311
05	OUTER DRIVE RING	1	ADC-12	φ41X26	
04-1	THRUST PAD	1	RULON	φ12X2.5	
04	IMPELLER VANE	1	PVDF	φ43X22.5	1001112305
03-1	SPINDLE	1	CERAMIC	φ4X27	1001212306
03	REAR CASING	1	PVDF	φ54X20.5	1001212305
02-1	FRONT THRUST PAD	1	CERAMIC	φ10X2	
02	FRONT CASING	1	PVDF	HOSE THREAD	1001112310 1011112300
01	MOTOR	1	BRUSH LESS 10 W	DC 12 V DC 24 V	1301212317

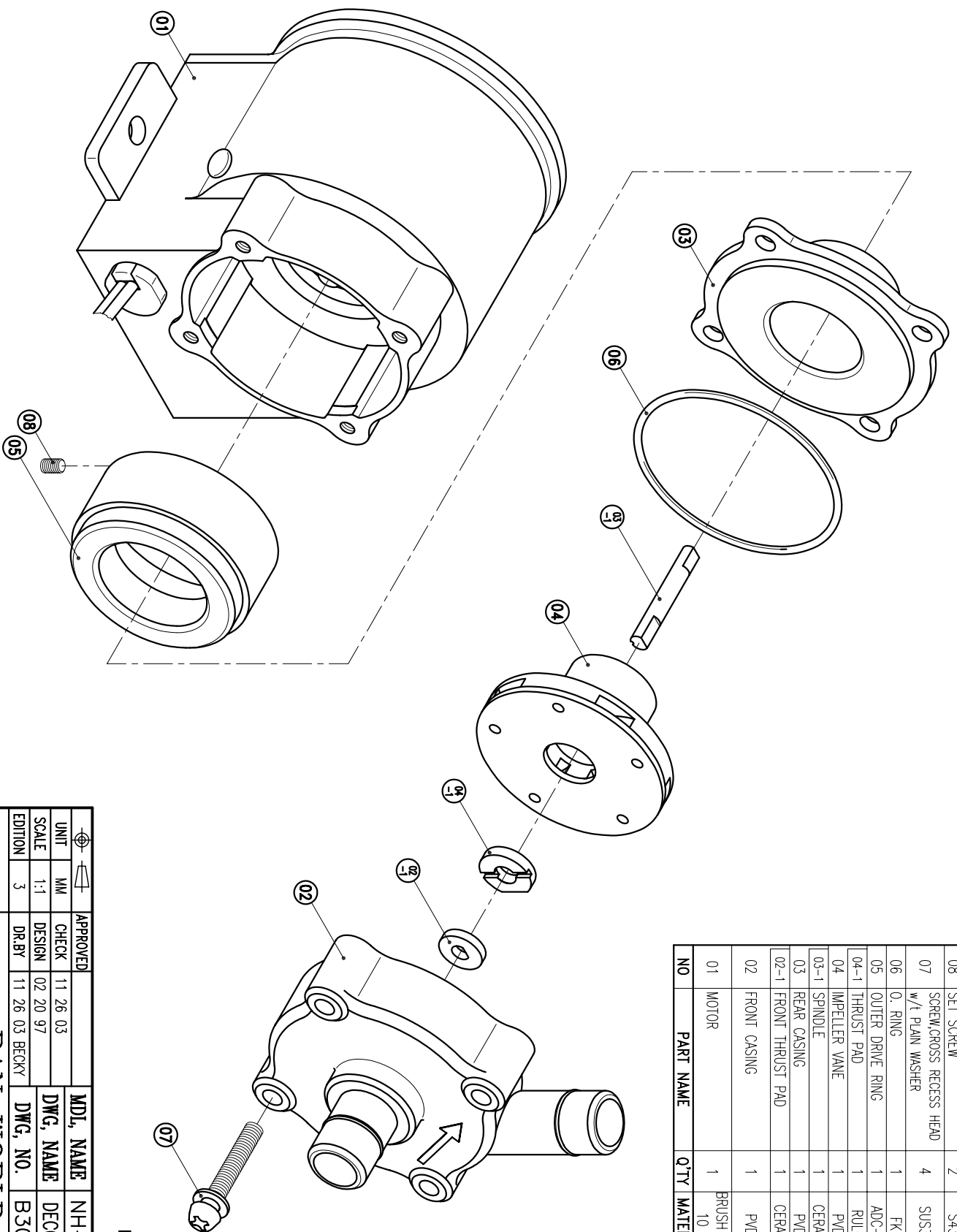

G : 1/2"X 1/2"  
NPT : 1/2"X 1/2"

APPROVED	CHECK	MDL NAME	DR.BY	DWG. NO.
	11 26 03	NH-5PX-Z-D-N	11 26 03 BECKY	B3001659
UNIT	SCALE	DWG. NAME	EDITION	DWG. NO.
MM	1:1	DESIGN	3	B3001659
		DR.BY		A3

TPW  
HONG YUAN

**PAN WORLD CO.,LTD.**  
パンワールド株式会社