

03-1	REAR THRUST PAD	1	TEFLON	φ12Xφ6X3	P2329477	04-2	BEARING	1	SIC	φ11X31	P2461767	08	SET SCREW	2	S435	M4X5	P9119420
03	REAR CASING	1	PVDF	φ74X47	P2301038	04-1	INNER MAGNET	1	CERAMIC	φ31X25	P2461481	07	SCREW,GROSS RECESS HEAD w/L P.W.(φ8Xφ4.3X10.8)	4	SUS304	M4X15	A9111026
02-1	FRONT THRUST PAD	1	SIC	φ10Xφ3X3	P2221118	04	IMPELLER VANE	1	FERRITE	φ44.5X44	P2441485	06	O. RING	1	FKM	φ62.5Xφ2	S63
02	FRONT CASING	1	TEFLON	φ74X46	P2221021			1	PVDF	φ44.5X44	P2401198	05-2	OUTER MAGNET	1	FERRITE	φ52Xφ40X25	P2521486
01	MOTOR	1	PVDF	φ74X46	P2211037	03-2	SPINDLE	1	SIC	φ6X35	P2331290	05-1	MAGNET HOUSING	1	ADC-12	φ56Xφ8X45	P2511002
											P2331479	05	OUTER DRIVE RING	1	φ56X54.5	P2501197	
NO	PART NAME	QTY	MATERIAL	NOTE	DWG. NO.	NO	PART NAME	QTY	MATERIAL	NOTE	DWG. NO.	NO	PART NAME	QTY	MATERIAL	NOTE	DWG. NO.

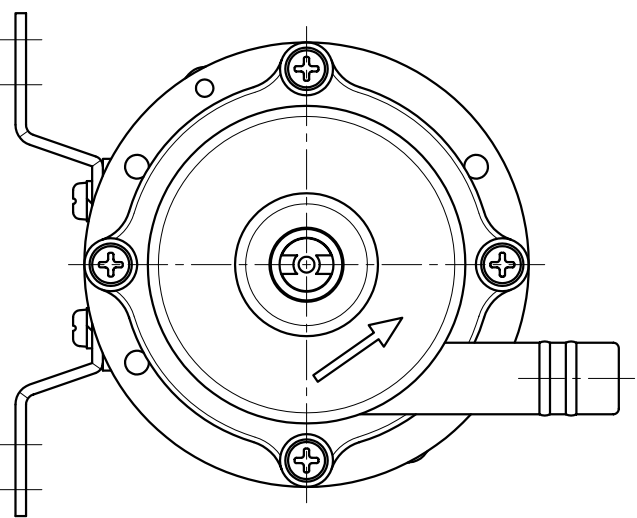
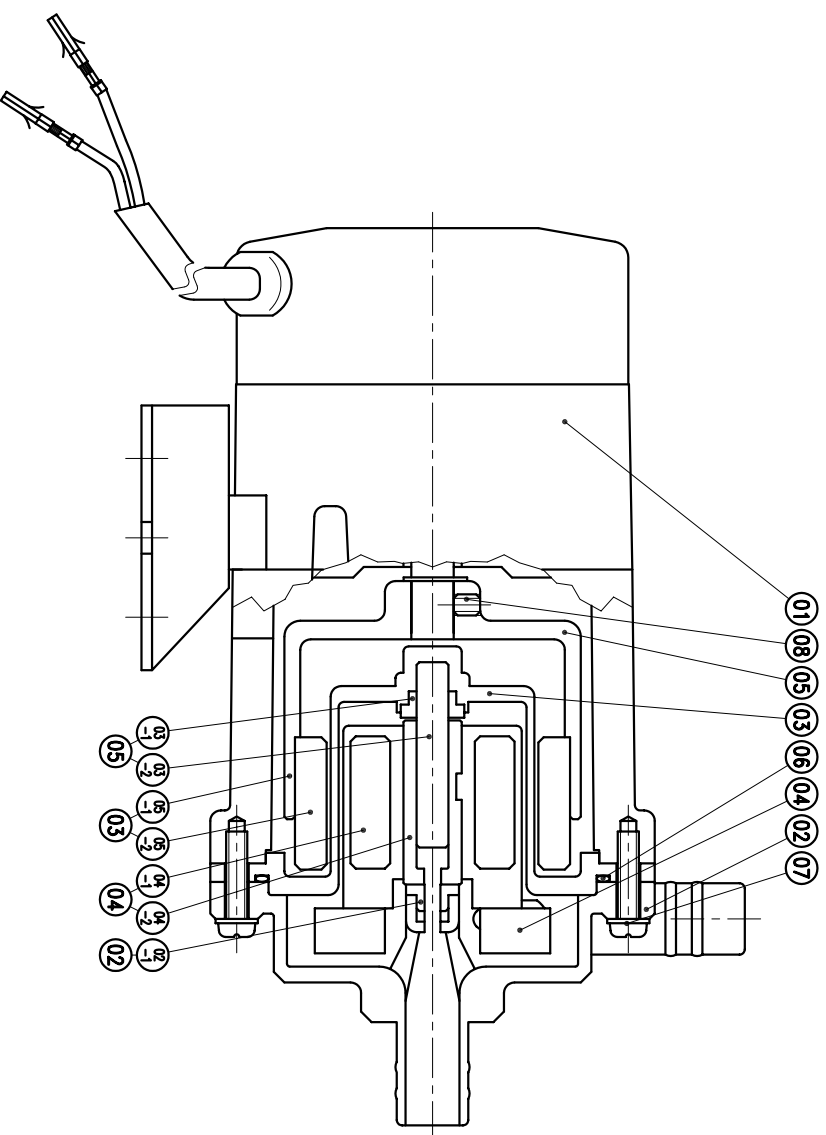

G : 3/4"X 3/4"
NPT : 3/4"X 3/4"

APPROVED	CHECK	08 03 02	MDL NAME	NH-30PX-D-N
CHECK	DESIGN	10 23 96	DWG. NAME	CONSTRUCTION DRAWING
SCALE	DR.BY	08 03 02 BECKY	DWG. NO.	B2031248
EDITION				A3

TPW
HONG YUAN



PAN WORLD CO., LTD.
パンワールド株式会社