

02-1	FRONT THRUST PAD	1	RULON	φ9Xφ4.2X1.2	A2221580
02	FRONT CASING	1	PVDF	φ54X38	P2201034
01	MOTOR			BRUSH LESS , 11.5W , DC72V , DC24V	
NO	PART NAME	QTY	MATERIAL	NOTE	DWG. NO.

05	OUTER DRIVE RING	1		φ41X26	P2501199	08	SET SCREW	2	S435	M3X4	P9111421
04-1	INNER MAGNET	1	FERRITE	φ18X12	P2441115	07	SCREW,GROSS RECESS HEAD w/L P.W.(φ8Xφ4.3X10.8)	4	SUS304	M4X25	A9111026
04	IMPELLER VANE	1	PPG	φ40X22.5	P2401035	06	O. RING	1	FKM	φ44.5Xφ2	S45
03-1	SPINDLE	1	SIC	φ4X27	P2331103	05-2	OUTER MAGNET	1	FERRITE	φ38Xφ25X10	P2521094
03	REAR CASING	1	PVDF	φ54X20.5	P2301036	05-1	MAGNET HOUSING	1	ADC-12	φ41Xφ5X21	P2511004
NO	PART NAME	QTY	MATERIAL	NOTE	DWG. NO.	NO	PART NAME	QTY	MATERIAL	NOTE	DWG. NO.

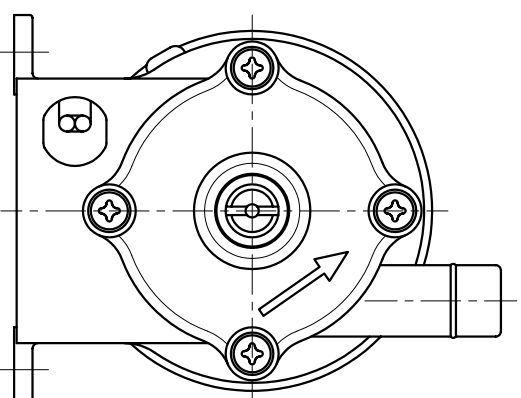
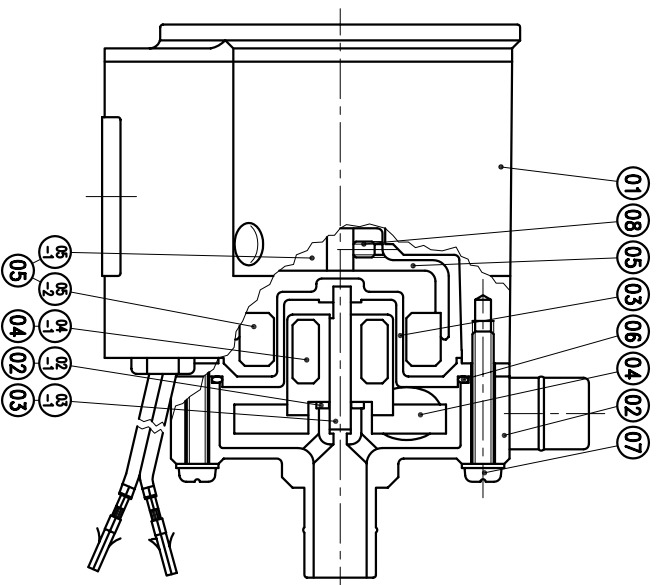

G : 1/2"X 1/2"
NPT : 1/2"X 1/2"

APPROVED		MDL NAME	NH-10PX-D-N
CHECK	12 31 03	DWG. NAME	CONSTRUCTION DRAWING
DESIGN	10 23 96	DWG. NO.	B2011247
DR.BY	12 31 03 BECKY		A3

TPW
HONG YUAN



PAN WORLD CO.,LTD.
パンワールド株式会社