

03-1	REAR THRUST PAD	1	ETFE			
03	REAR CASING	1	ETFE	Ø1X39.5	P2301047	
02-1	FRONT THRUST PAD	1	SIC	Ø10XØ6X6	P2229119	
02	FRONT CASING	1	ETFE	Ø12XØ6X6	P2229765	
01	MOTOR		BRUSH LESS , 29W , DC24V	Ø1X48.5	P2211043	

04-4	IMPELLER COVER	1	ETFE	Ø76X6	P2451044	
04-3	INNER MAGNET	1	FERRITE	Ø56XØ17X30	P2449487	
04-2	MOUTH RING	1	RIJON	Ø77X4.5	P2421462	
04-1	IMPELLER VANE	1	ETFE	Ø76X34	P2411045	
04	IMPELLER ASS'Y	1	ETFE	Ø59X59.5	P2401195	
03-2	SPINDLE	1	SIC	Ø6X50	P2339480	
			CERAMIC		P2339291	

08	SET SCREW	2	S435	M4X5	P9119420	
07	SCREW,GROSS RECESS HEAD w/L.P.W.(Ø10XØ5.3X11)	6	SUS304	M5X28	P9111136	
06	O. RING	1	FKM	Ø79.5X2	S80	
05-2	OUTER MAGNET	1	FERRITE	Ø66X30	P2529488	
05-1	MAGNET HOUSING	1	ADC-12	Ø70X48.5	P2519003	
05	OUTER DRIVE RING	1	SIC	Ø70X63.5	P2509196	
04-5	BEARING	1	CERAMIC	Ø11X31	A2469157	
					P2469482	

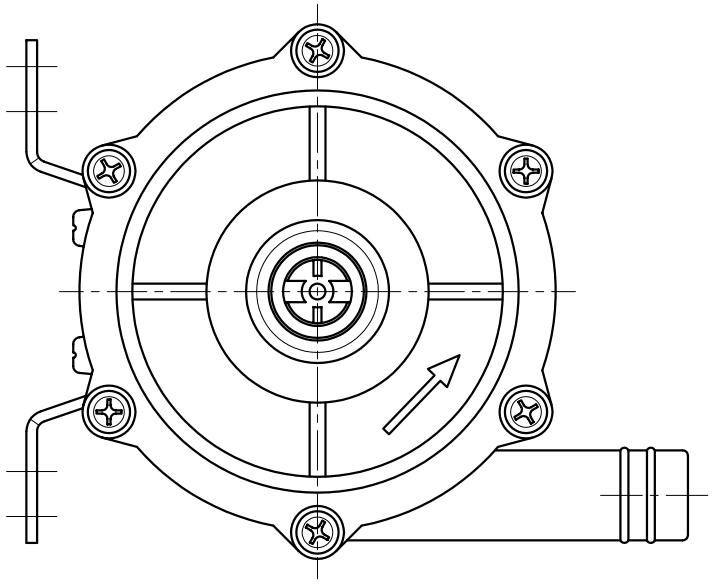
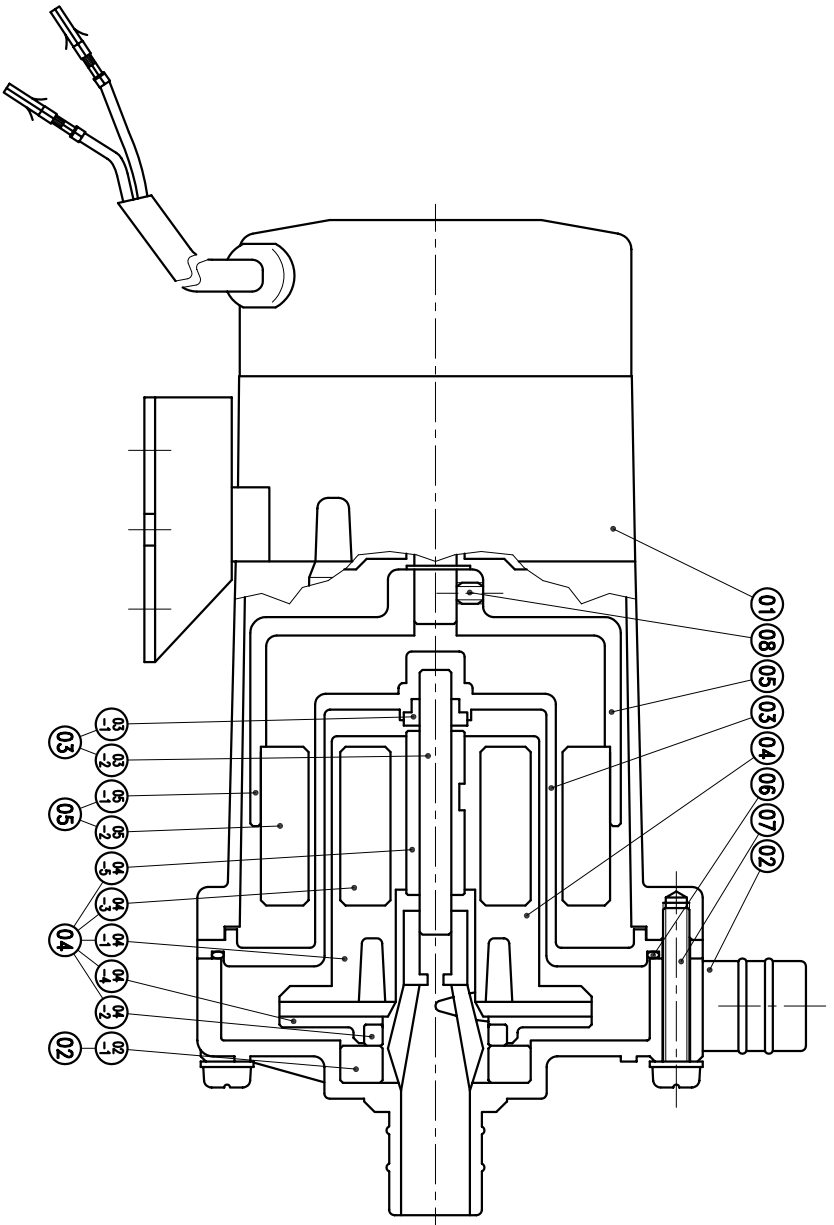

G : 3/4"X 3/4"
NPT : 3/4"X 3/4"

APPROVED	CHECK	08 05 02	MDL NAME	NH-50PX-Z-D-F
SCALE	DESIGN	06 01 97	DWG. NAME	CONSTRUCTION DRAWING
EDITION	DR.BY	08 05 02 BECKY	DWG. NO.	B2051550
				A3

TPW
HONG YUAN



PAN WORLD CO., LTD.
パンワールド株式会社