

NO	PART NAME	QTY	MATERIAL	NOTE	PART NO.
05-1	RING	1	S45C	φ48X9.8	
05	OUTER DRIVE RING	1	FCD-45	φ122X205	1003511800
04	IMPELLER ASS'Y	1	PPG		1003411000
03	REAR CASING	1	PPG	φ186.5X140	1003912360
02-2	FLANGE	1	PPG	40A	1003011600
02-1	FLANGE	1	PPG	50A	1003912310
02	FRONT CASING	1	PPG	φ202X113	1003212300
01	BRACKET	1	FC-20	φ202X208	1003013101

17	HEAXGON SOCKET BOLT	4	SUS304	1/2" - 13X1"	
16	w/t SPRING WASHER	1	S435	M6X10	
15	SET SCREW	2	S435	M8X10	
14	HEAXGON HEAD BOLT	5	SUS304	M10X35	
13	w/t PLAIN WASHER	3	SUS304	M10X65	
12	O. RING	1	FKM	G45	1003012200
11	O. RING	1	FKM	G50	1003912311
10	O. RING	1	FKM	G175	1003012302
09-2	PTFE BOARD	1	PTFE	281.8X122.9	
09-1	PTFE BOARD	1	PTFE	278.6X122.9	
09	PTFE BOARD	2	PTFE	LX122.9	A2119713
08	REAR CASING COVER ASS'Y	1		φ164X137	1004912308
07	INNER DRIVE RING	1	PPG	φ79.6X124	
06	BEARING ASS'Y	1	CERAMIC		1003210803
			RULON	φ44X46.5	1003210802
			CARBON		1003210801

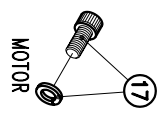
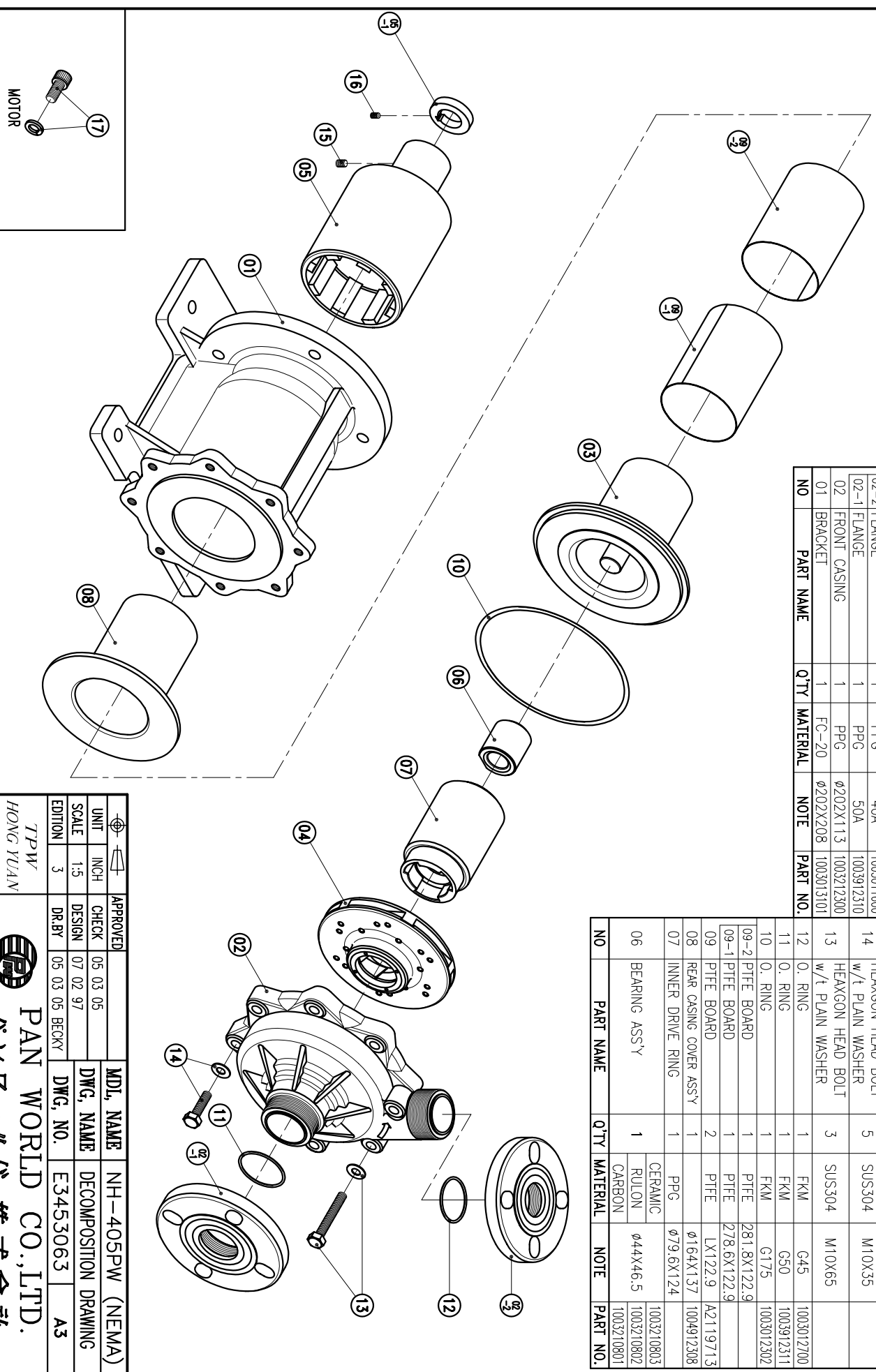

APPROVED	CHECK	DESIGN	DR.BY	MDL. NAME	DWG. NAME	DWG. NO.	POSITION
	05 03 05	07 02 97	05 03 05 BECKY	NH-405PW (NEMA)	DECOMPOSITION DRAWING	E3453063	A3

TPW
 HONG YUAN

PAN WORLD CO., LTD.
パンワールド株式会社