

NO	PART NAME	Q'TY	MATERIAL	NOTE	PART NO.
05-1	RING	1	S45C	φ44X10	
05	OUTER DRIVE RING	1	FCD-45	φ118X183.5	1003311800
04	IMPELLER ASS'Y	1	PPG		1003311000
03	REAR CASING	1	PPG	φ186.5X141	1003912360
02	FRONT CASING	1	PPG	φ202X113	1003212300
01	BRACKET	1	FC-20	φ202X186.5	1003012101

14	HEAXGON SOCKET BOLT	4	SUS304	3/8" - 16X1"	
13	w/t SPRING WASHER	1	S435	M6X10	
12	SET SCREW	2	S435	M8X10	
11	HEAXGON HEAD BOLT	5	SUS304	M10X35	
10	w/t PLAIN WASHER	3	SUS304	M10X65	
09	O. RING	1	FKM	G175	1003012302
08	BACK UP RING	1	SUS304	φ164X5.5	1003012100
07	INNER DRIVE RING	1	PPG	φ79.6X124	
06	BEARING ASS'Y	1	CERAMIC RULON CARBON	φ44X46.5	1003210803 1003210802 1003210801

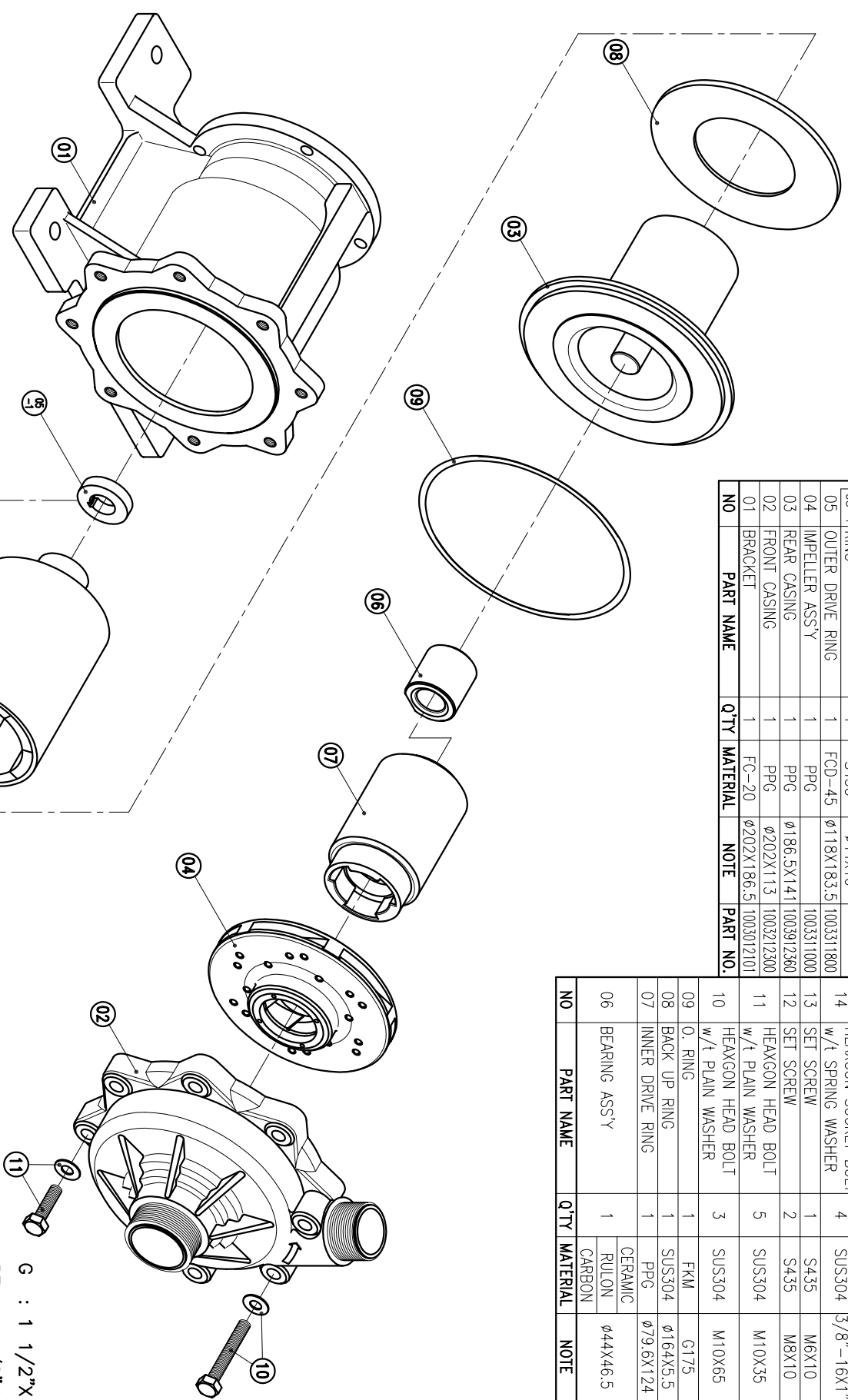

G : 1 1/2" X 2"  
NPT : 1 1/2" X 2"

APPROVED	CHECK	DESIGN	DR.BY	MDL NAME	DWG. NAME	DWG. NO.	DECOMPOSITION DRAWING
	09 01 03	04 18 02	09 01 03 BECKY	NH-403PW (NEMA)		E34353067	A3

TPW  
HONGYUAN



PAN WORLD CO., LTD.  
パンワールド株式会社

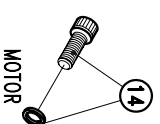

MOTOR