

NO	PART NAME	Q'TY	MATERIAL	NOTE	PART NO.
05-1	RING	1	S45C	φ40X7.5	
05	OUTER DRIVE RING	1	FCD-45	φ12.3X127.5	100311800
04	IMPELLER ASS'Y	1	PPG		1003111000
03	REAR CASING	1	PPG	φ174X92.5	1003110200
02-1	FLANGE	2	PPG	40A	100301600
02	FRONT CASING	1	PPG	φ185X124	1003112300
01	BRACKET	1	FC-20	φ185X128	1003011100

15	HEAXGON SOCKET BOLT	4	SUS304	3/8" - 16X1"	
14	w/t SPRING WASHER	1	S435	M6X10	
13	SET SCREW	2	S435	M8X10	
12	HEAXGON HEAD BOLT	6	SUS304	M8X30	
11	w/t PLAIN WASHER	2	SUS304	M8X35	
10	O. RING	2	FKM	G45	1003012700
09	O. RING	1	FKM	G160	1003012301
08	BACK UP RING	1	SUS304	φ150X5.5	1003113300
07	INNER DRIVE RING	1	PPG	φ79.6X71	1003010812
06	BEARING ASS'Y	1	CERAMIC RULON CARBON	φ44X31	1003010811 1003010810

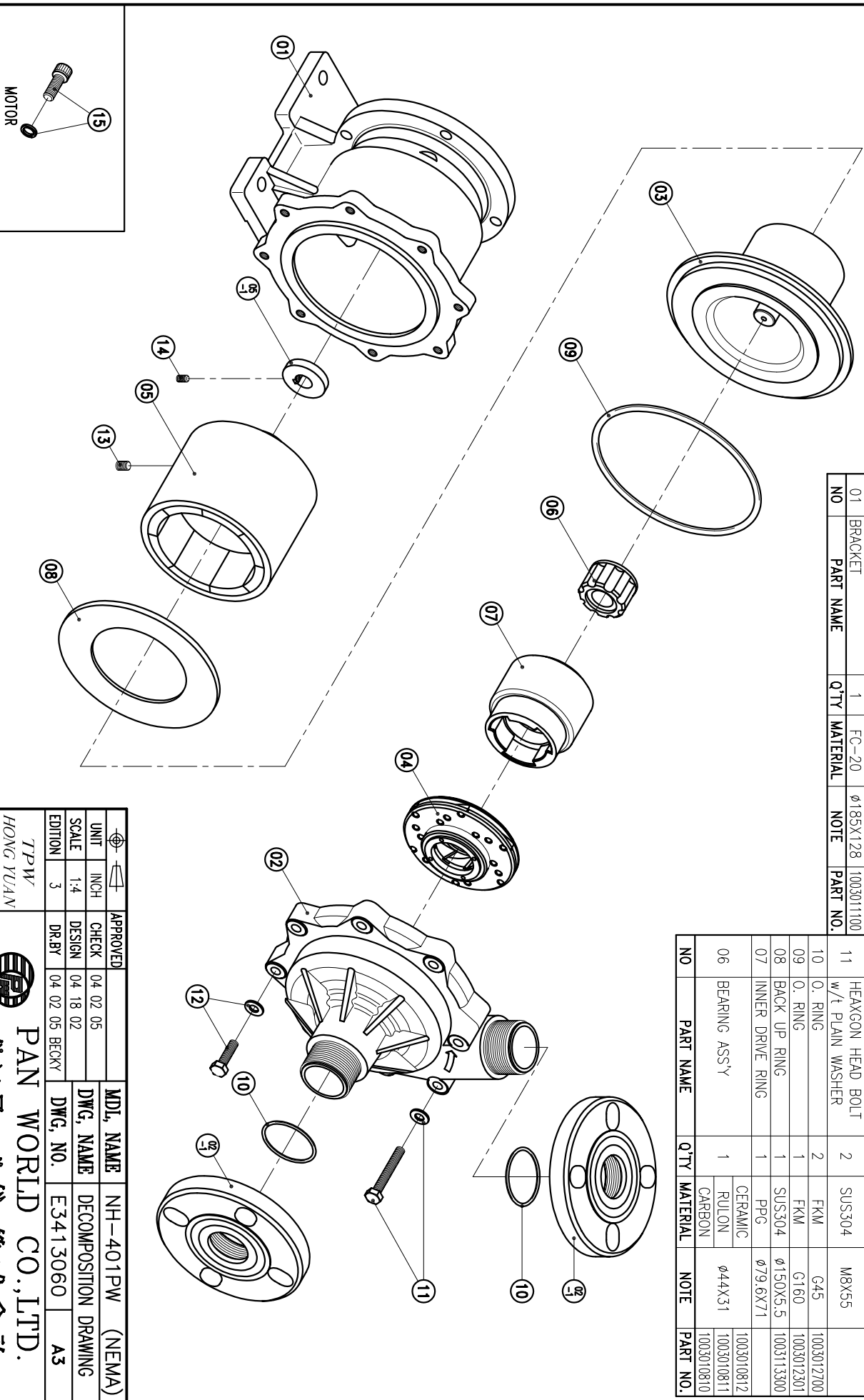

APPROVED	CHECK	DESIGN	DR.BY	MDL. NAME	DWG. NAME	DWG. NO.
	04 02 05	04 18 02	04 02 05 BECKY	NH-401PW (NEMA)	DECOMPOSITION DRAWING	E3413060
						A3

TPW  
HONG YUAN



PAN WORLD CO., LTD.  
パンワールド株式会社