

NO	PART NAME	Q'TY	MATERIAL	NOTE	DWG. NO.	NO	PART NAME	Q'TY	MATERIAL	NOTE	DWG. NO.
03-4	O. RING	1	FKM	φ24.4Xφ3.1	G25	08-3	COVER	1	SUS304	φ90.4X12	A2119715
03-3	SPINDLE	1	CERAMIC	φ25X125	P2339005	08-2	PIPE	1	HASTELLOY C	φ90.4X133.5	A2119712
03-2	REAR THRUST PAD	1	CERAMIC	φ37X8	P2329184	08-1	BACK UP RING	1	SUS304	φ210X8.5	A2119285
03-1	SPINDLE HOLDER	1	ETFE	φ41X131	P2379483	08	REAR CASING COVER ASS'Y	1		φ210X137	P2114731
03	REAR CASING	1	ETFE	φ240X141	P2304738	07-1	INNER MAGNET	1	Nd-Fe-B	φ76X93	P2444492
02-6	SLEEVE	2	SUS304	φ20X21.5	A2273365	07	INNER DRIVE RING	1	ETFE	φ79.6X124	P2439018
02-5	SLEEVE	6	SUS304	φ20X50	A2273365	06-1	BEARING	1	CERAMIC	φ36X45	P2469183
02-4	RELIEF PLATE	1	FC-20	φ261X12	A2273364	06	BEARING ASS'Y	1	CARBON	φ44X46.5	P2469773
02-3	FLANGE	1	PPG	65A	P2233892	05	OUTER DRIVE RING	1	ETFE	φ122X245.1	A2469553
02-2	FLANGE	1	PPG	80A	P2233893	04-3	IMPELLER COVER	1	FCD-45	φ122X245.1	P2504347
02-1	FRONT THRUST PAD	1	CERAMIC	φ104X9	P2224475	04-2	IMPELLER RING	1	ETFE	φ175X20	P2454028
02	FRONT CASING	1	PPG	φ261X148	A2203366	04-1	IMPELLER NOUWENON	1	RULON	φ104X9	P2424412
01-1	TRANSITION FLANGE	1	FC-20	φ254X21.6	P2179309	04	IMPELLER ASS'Y	1	ETFE	φ175X44	P2414022
01	BRACKET	1	FC-20	φ261X226.5	A2123379	09	PTFE BOARD	2	PTFE	LX122.9	A2119713

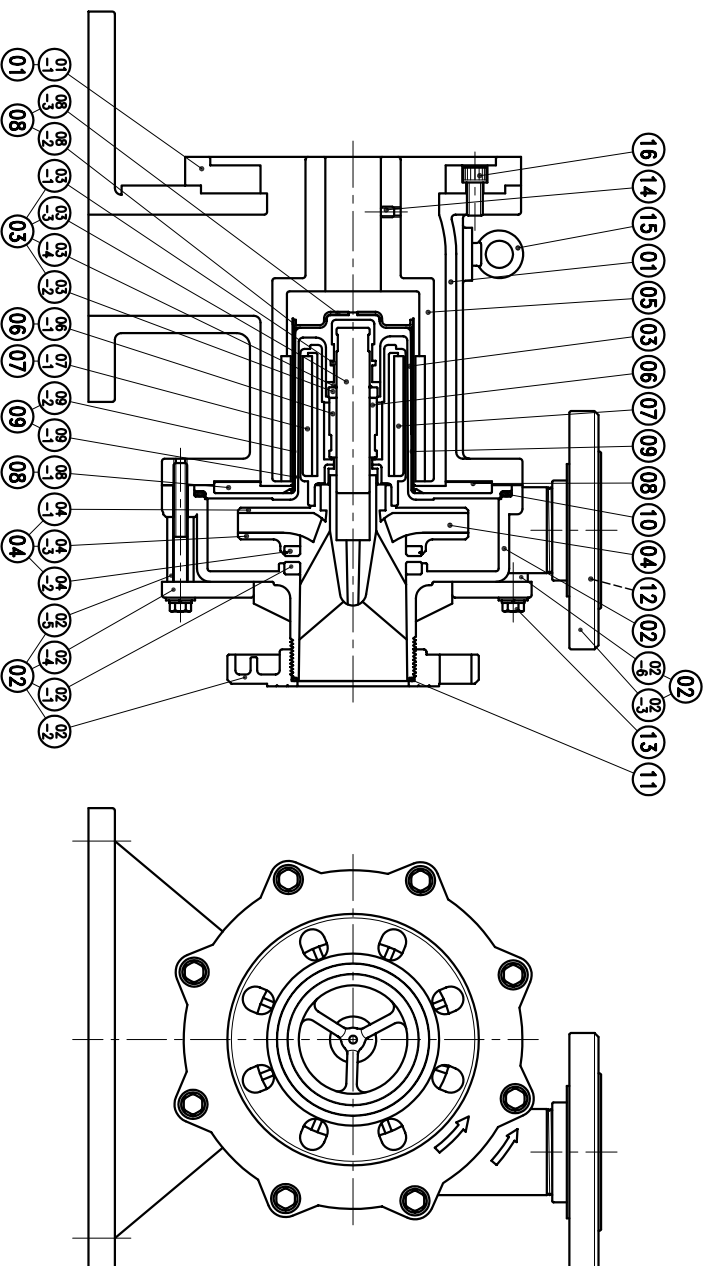

APPROVED		MDL NAME	NH-6515PW (NEMA)
CHECK	05 03 05	DWG. NAME	CONSTRUCTION DRAWING
DESIGN	03 14 00	DWG. NO.	E2693077
DR.BY	05 03 05 BECKY		A3

TPW  
HONG YUAN



PAN WORLD CO., LTD.  
パンワールド株式会社