

NO	PART NAME	Q'TY	MATERIAL	NOTE	DWG. NO.	NO	PART NAME	Q'TY	MATERIAL	NOTE	DWG. NO.
04-2	MOUTH RING	1	RULON	φ63X8	P2429006	08-3	COVER	1	SUS304	φ90.4X12	A2119715
04-1	IMPELLER NOUМЕНON	1	PPG	φ160X44	P2419024	08-2	PIPE	1	HASTELLOY	φφ90.4X122.5	A2119716
04	IMPELLER ASS'Y	1	PPG		P2409029	08-1	BACK UP RING	1	SUS304	φ164X5.5	A2119714
03-4	O. RING	1	FKM	φ24.4Xφ3.1	G25	08	REAR CASING COVER	1		φ164X1.37	A2119717
03-3	SPINDLE	1	CERAMIC	φ25X125	P2339005	07-1	INNER MAGNET	1	Nd-Fe-B	φ76X93	P2449491
03-2	REAR THRUST PAD	1	CERAMIC	φ37X8	P2329184	07	INNER DRIVE RING	1	PPG	φ79.6X124	P2439018
03-1	SPINDLE HOLDER	1	PPG	φ41X131	P2379483	06-1	BEARING	1	CERAMIC CARBON RULON	φ36X45	P2469183 P2469173 A2469348
03	REAR CASING	1	PPG	φ186.5X140	P2309737	06	BEARING ASS'Y	1	ETFE	φ44X46.5	A2469553
02-1	FRONT THRUST PAD	1	CERAMIC	φ72X9	P2229315	05-1	RING	1	S45C	φ48X9.8	P2579342
02	FRONT CASING	1	PPG	φ202X113	P2203180	05	OUTER DRIVE RING	1	FCD-45	φ122X205	P2509341
01	BRACKET	1	FC-20	φ202X221	A2123121	04-3	IMPELLER COVER	1	PPG	φ160X25	P2459026

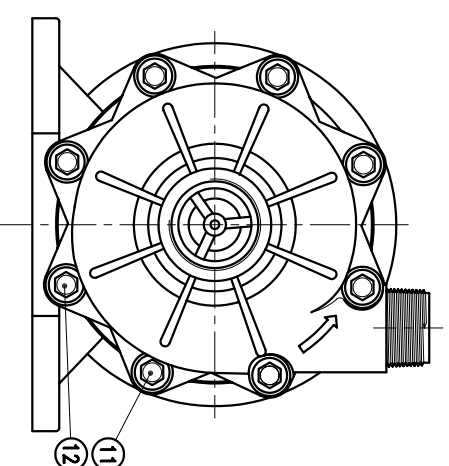
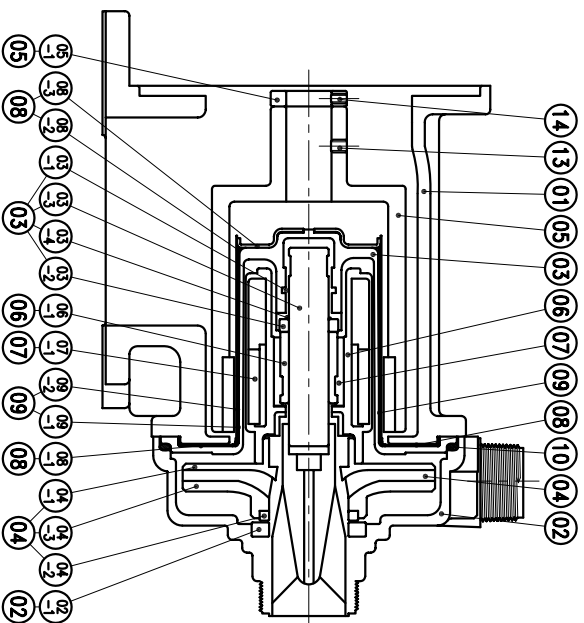

G : 1 1/2" X 2"
NPT : 1 1/2" X 2"

APPROVED	CHECK	DESIGN	DR.BY	MDL. NAME	DWG. NAME	DWG. NO.
	05 03 05	11 23 96	05 03 05 BECKY	NH-405PW (NEMA)	CONSTRUCTION DRAWING	E2453029
UNIT	INCH	SCALE	3:10	EDITION	5	

TPW
HONG YUAN



PAN WORLD CO., LTD.
パンワールド株式会社