

NO	PART NAME	Q'TY	MATERIAL	NOTE	DWG. NO.	NO	PART NAME	Q'TY	MATERIAL	NOTE	DWG. NO.
04	IMPELLER ASS'Y	1	PPG		P2409177	08	BACK UP RING	1	SUS304	Ø164X5.5	P2119175
03-4	O. RING	1	FKM	Ø24.4XØ3.1	G25	07-1	INNER MAGNET	1	S-FERRITE	Ø76X93	P2449490
03-3	SPINDLE	1	CERAMIC	Ø25X125	P2339005	07	INNER DRIVE RING	1	PPG	Ø79.6X124	P2439018
03-2	REAR THRUST PAD	1	CERAMIC	Ø37X8	P2329184	06-1	BEARING	1	CERAMIC CARBON RULON	Ø36X45	P2469183 P2469173 A2469348
03-1	SPINDLE HOLDER	1	PPG	Ø41X131	P2379483	06	BEARING ASS'Y	1	ETFE	Ø44X46.5	A2469553
03	REAR CASING	1	PPG	Ø186.5X141	P2309178	05-1	RING	1	S45C	Ø44X10	P2579340
02-3	FLANGE	1	PPG	40A	P2233172	05	OUTER DRIVE RING	1	FCD-45	Ø118X183.5	P2509335
02-2	FLANGE	1	PPG	50A	P2233411	04-3	IMPELLER COVER	1	PPG	Ø160X25	P2459026
02-1	FRONT THRUST PAD	1	CERAMIC	Ø72X9	P2229315	04-2	MOUTH RING	1	RULON	Ø63X8	P2429006
02	FRONT CASING	1	PPG	Ø202X113	P2203180	04-1	IMPELLER NOUМЕНON	1	PPG	Ø160X44	P2419024
01	BRACKET	1	FC-20	Ø202X196.5	A2123148	09	O. RING	1	FKM	Ø174.3XØ5.7	G175

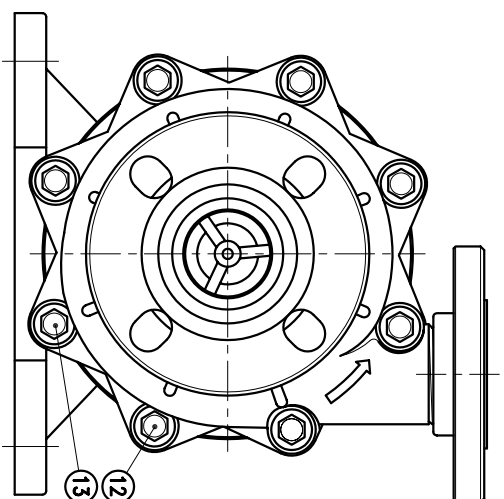

APPROVED		MDL NAME	NH-403PW (NEMA)
CHECK	02.16.04	DWG. NAME	CONSTRUCTION DRAWING
DESIGN	10.23.96	DWG. NO.	E2433072
DR.BY	02.16.04 BECKY		A3

TPW  
HONG YUAN

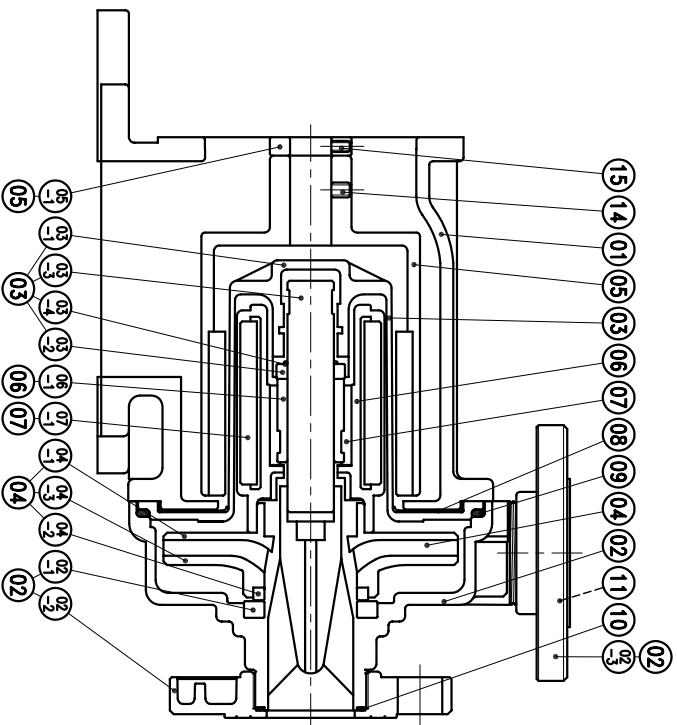

PAN WORLD CO., LTD.  
パンワールド株式会社