

04	IMPELLER ASS'Y	1	PPG	P2409177	07-1	INNER MAGNET	1	ST.FERRITE	Ø76X93	P2449490	14	HEXAGON SOCKET BOLT	SUS304	3/8" - 16X1"	A9119380		
03-4	O. RING	1	FKM	Ø24.4XØ3.1	07	INNER DRIVE RING	1	PPG	Ø79.6X124	P2439018	13	SET SCREW	S435	M6X10	P9116430		
03-3	SPINDLE	1	CERAMIC	Ø25X125		BEARING	1	CERAMIC CARBON RULON	Ø36X45	P2469183 P2469773 A2469348	12	SET SCREW	S435	M8X10	P9119160		
03-2	REAR THRUST PAD	1	CERAMIC	Ø37X8		BEARING ASS'Y	1	ETFE	Ø44X46.5	A2469553	11	HEXAGON HEAD BOLT	SUS304	M10X35	P9113080		
03-1	SPINDLE HOLDER	1	PPG	Ø41X131	06	BEARING ASS'Y	1	S45C	Ø44X10	P2579340	10	HEXAGON HEAD BOLT	SUS304	M10X65	P9113080		
03	REAR CASING	1	PPG	Ø186.5X141	05-1	RING	1	FCD-45	Ø118X183.5	P2509335	10	W/1 P.W.(Ø21XØ10.5X12)	SUS304	M10X65	P9113080		
02-1	FRONT THRUST PAD	1	CERAMIC	Ø72X9	05	OUTER DRIVE RING	1	PPG	Ø160X27.8	P2459060	09	Ø RING	FKM	Ø174.3XØ5.7	G175		
02	FRONT CASING	1	PPG	Ø202X113	04-3	IMPELLER COVER	1	PPG	Ø63X8	P2429006	08	BACK UP RING	SUS304	Ø164X5.5	P2119175		
01	BRACKET	1	FC-20	Ø202X196.5	04-2	MOUTH RING	1	RULON	Ø160X44	P2419024	08	BACK UP RING	SUS304	Ø164X5.5	P2119175		
NO	PART NAME	Q'TY	MATERIAL	NOTE	DWG. NO.	NO	PART NAME	Q'TY	MATERIAL	NOTE	DWG. NO.	NO	PART NAME	Q'TY	MATERIAL	NOTE	DWG. NO.

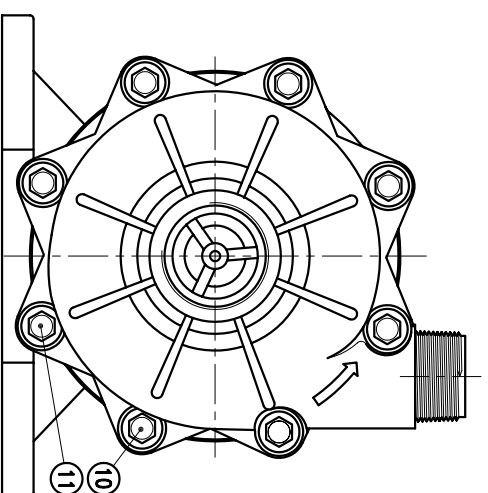
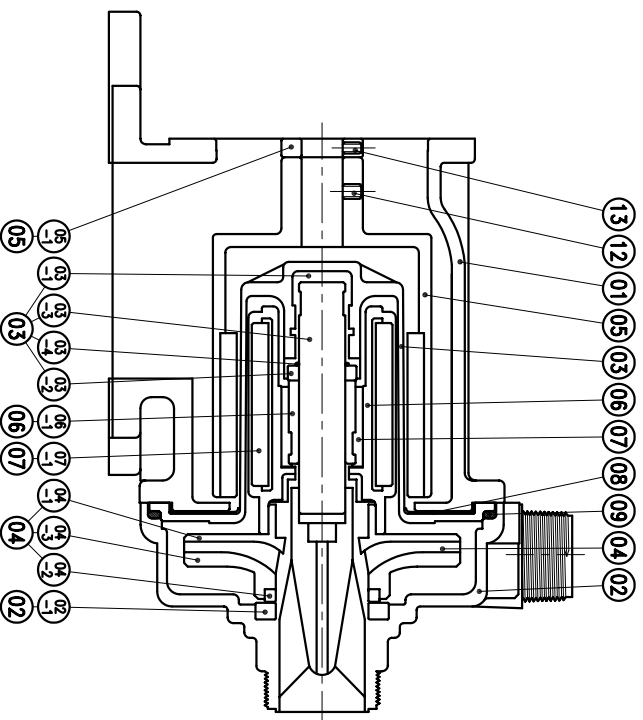

G : 1 1/2" X 2"
NPT : 1 1/2" X 2"

APPROVED		MDL NAME	NH-402PW (NEMA)
CHECK	02.16.04	DWG. NAME	CONSTRUCTION DRAWING
DESIGN	10.23.96	DWG. NO.	E2423080
DRBY	02.16.04 BECKY		A3

TPW
HONG YUAN



PAN WORLD CO., LTD.
パンワールド株式会社