

NO	PART NAME	Q'TY	MATERIAL	NOTE	DWG. NO.	NO	PART NAME	Q'TY	MATERIAL	NOTE	DWG. NO.
04	IMPELLER ASS'Y	1	PPG	P2409050		07-1	INNER MAGNET	1	ST-FERRITE	Ø76X47	P2449053
03-4	O. RING	1	FKM	Ø19.8XØ2.4	P20	07	INNER DRIVE RING	1	PPG	Ø79.6X71	P2439077
03-3	SPINDLE	1	CERAMIC	Ø20X6.5	P2339096	06-1	BEARING	1	CERAMIC	Ø52X28	P2469770
03-2	REAR THRUST PAD	1	CERAMIC	Ø36X6.5	P2329095		CARBON RULON			P2469771	
03-1	SPINDLE HOLDER	1	PPG	Ø40X68	P2379093	06	BEARING ASS'Y	1	ETFE	Ø44X31	P2469076
03	REAR CASING	1	PPG	Ø174X92.5	P2309020	05-1	RING	1	S45C	Ø40X7.5	P2579333
02-2	FLANGE	2	PPG	40A	P223172	05	OUTER DRIVE RING	1	FCD-45	Ø123X127.5	P2509354
02-1	FRONT THRUST PAD	1	CERAMIC	Ø58X8.5	P2229092	04-3	IMPELLER COVER	1	PPG	Ø124X18	P2459052
02	FRONT CASING	1	PPG	Ø185X124	P2203048	04-2	MOUTH RING	1	RULON	Ø52X7	P2429098
01	BRACKET	1	FC-20	Ø185X140.4	A2123147	04-1	IMPELLER NOUWENON	1	PPG	Ø124X33	P2419051
						08	BACK UP RING	1	SUS304	Ø150X5.5	P2119054
						15	HEXAGON SOCKET BOLT	4	SUS304	3/8" - 16X1"	A9119380
						14	SET SCREW	1	S435	w/1 S.W.(3/8") (MOTOR)	
						13	SET SCREW	2	S435	M8X10	P9116430
						12	HEXAGON HEAD BOLT	6	SUS304	M8X30	P9113079
						11	HEXAGON HEAD BOLT	2	SUS304	M8X55	P9113079
						10	O. RING	2	FKM	Ø44.4XØ3.1	G45
						09	O. RING	1	FKM	Ø159.3XØ5.7	G160

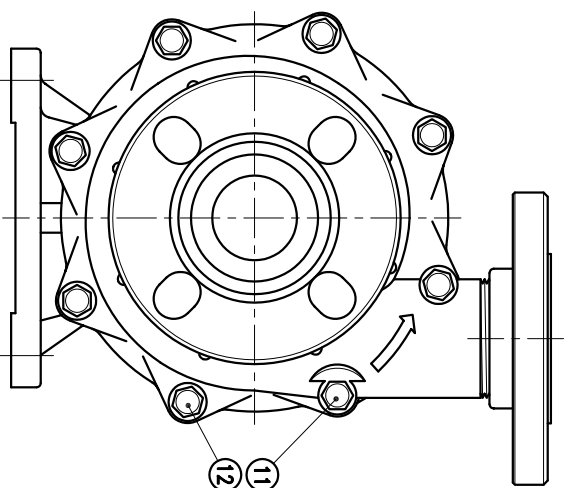
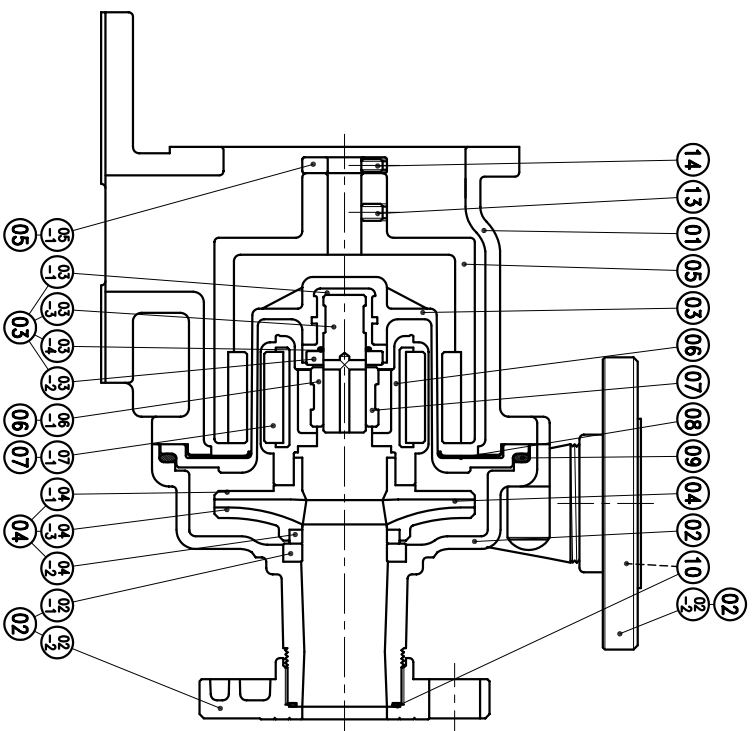

APPROVED	CHECK	DESIGN	DR.BY	MDL. NAME	DWG. NAME	DWG. NO.
04 02 05	04 02 05	10 22 96	04 02 05 BECKY	NH-401PW (NEMA)	CONSTRUCTION DRAWING	E2413070
UNIT	INCH	SCALE	EDITION			
		2.5	3			

TPW
HONG YUAN

PAN WORLD CO., LTD.
PANワールド株式会社