

03-4	O. RING	1	FKM	φ19.8Xφ2.4	P20	07-1	INNER MAGNET	1	FERRITE	φ76X44.5	P2449101	15	HEXAGON SOCKET BOLT	4	SUS304	3/8" - 16X1"	A9119380
03-3	SPINDLE	1	CERAMIC	φ20X65	P2339096	07	INNER DRIVE RING	1	PPG	φ79.6X71	P2439077	14	SET SCREW	1	S435	M6X10	P9116430
03-2	REAR THRUST PAD	1	CERAMIC	φ36X6.5	P2329095	06-1	BEARING	1	CERAMIC CARBON	φ52X28	P2469770	13	SET SCREW	2	S435	M8X10	P9119160
03-1	SPINDLE HOLDER	1	PPG	φ40X68	P2379093	06	BEARING ASS'Y	1	ETFE	φ44X31	P2469076	12	HEXAGON HEAD BOLT	5	SUS304	M8X30	P9113079
03	REAR CASING	1	PPG	φ164X92.5	P2309073	05-1	RING	1	S45C	φ57.5X17.5	P2579332	11	HEXAGON HEAD BOLT	1	SUS304	M8X55	P9113079
02-2	FLANGE	2	PPG	40A	P2233172	04-3	IMPELLER COVER	1	PPG	φ105X18	P2459099	10	O. RING	2	FKM	φ44.3Xφ3.1	G45
02-1	FRONT THRUST PAD	1	CERAMIC	φ58X8.5	P2229092	04-2	IMPELLER NOUМЕНON	1	PPG	φ52X7	P2429098	09	O. RING	1	FKM	φ149.3Xφ5.7	G150
02	FRONT CASING	1	PPG	φ174X110	P2203102	04-1	IMPELLER ASS'Y	1	PPG	φ105X30	P2419097	08	BACK UP RING	1	SUS304	φ140X5.5	P2119089
01	BRACKET	1	FC-20	φ174X140.4	A2123146	04	IMPELLER ASS'Y	1	PPG	φ105X30	P2409074	08	BACK UP RING	1	SUS304	φ140X5.5	P2119089
NO	PART NAME	Q'TY	MATERIAL	NOTE	DWG. NO.	NO	PART NAME	Q'TY	MATERIAL	NOTE	DWG. NO.	NO	PART NAME	Q'TY	MATERIAL	NOTE	DWG. NO.

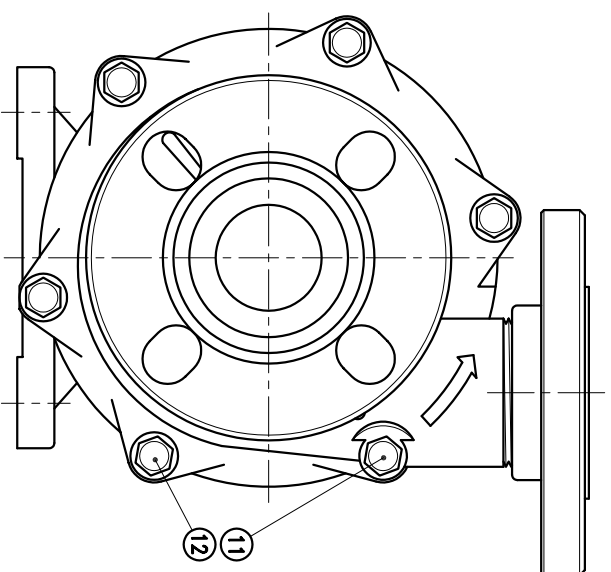

APPROVED	CHECK	04.02.05	MDL. NAME	NH-400PW (NEMA)	
UNIT	INCH		DWG. NAME	CONSTRUCTION DRAWING	
SCALE	1:2	DESIGN	10.22.96	DWG. NO.	E2403069
EDITION	3	DR.BY	04.02.05 BECKY		A3

TPW  
HONG YUAN

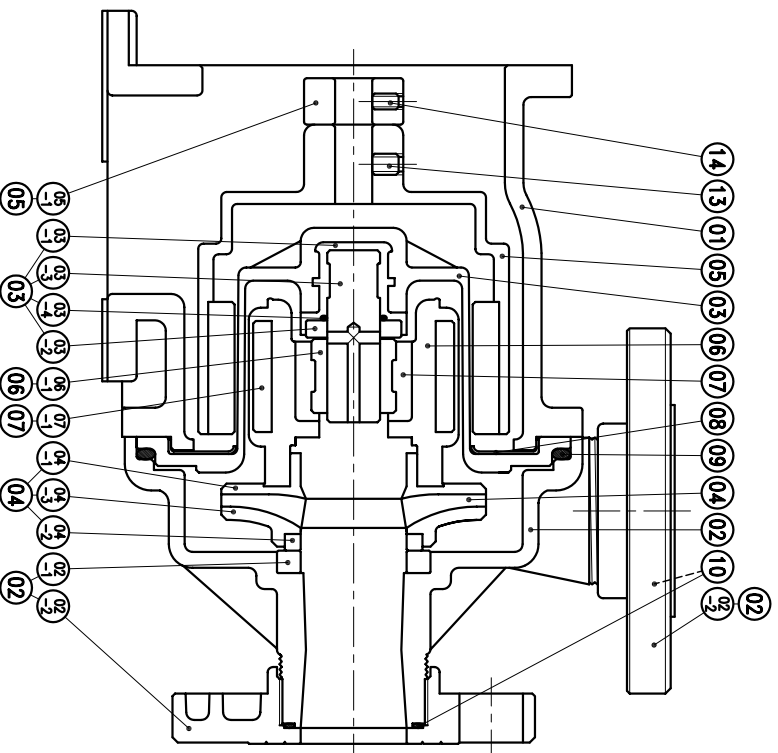

PAN WORLD CO., LTD.  
パンワールド株式会社