

NO	PART NAME	Q'TY	MATERIAL	NOTE	PART NO.
20	GASKET	1	FKM	293X218X4.5	
2C	TELESCOPIC PIECE	1	PPG	286X211X88	
2B-1	FILTER	1	PPG	164X77X60	
2B	REAR CASING CHAMBER	1	PPG	368X226X99	
2A-2	FILLER CAP	1	PPG	φ55X30	
2A-1	DRAIN CAP	1	PPG	φ36X24	
2A	FRONT CASING CHAMBER	1	PPG	342X226X152	
01	SELF-PRIMING CHAMBER	1	PPG	φ195X145	
02	BRACKET	1	FC-20		
10	O. RING	1	FKM	G30	
09	O. RING	1	FKM	G160	1003012301
08	BACK UP RING	1	SUS304	φ150X5.5	1003113300
07	INNER DRIVE RING	1	PPG	φ79.6X71	
06	BEARING ASS'Y	1	CARBON	φ44X31	
05-1	RING	1	S45C	φ57.5X17.5	
04	OUTER DRIVE RING	1	ADC-12	φ117.5X119	1003111800
05	IMPELLER ASS'Y	1	PPG		1003111000
03	REAR CASING	1	PPG	φ174X92.5	1003110200

NO	PART NAME	Q'TY	MATERIAL	NOTE	PART NO.
20	HEXAGON SOCKET BOLT w/1 SPRING WASHER	4	SUS304	3/8" - 16X1"	
19	SET SCREW	2	S435	M6X10	
18	SET SCREW	2	S435	M8X10	
17	NUT w/1 PLAIN WASHER	7	SUS304	M8	
16	HEXAGON HEAD BOLT w/1 SPRING WASHER w/1 PLAIN WASHER	3	SUS304	M8X30	
15	HEXAGON SOCKET BOLT w/1 SPRING WASHER w/1 PLAIN WASHER	6	SUS304	M8X70	
14	HEXAGON SOCKET BOLT w/1 SPRING WASHER w/1 PLAIN WASHER	1	SUS304	M8X130	
13	HEXAGON SOCKET BOLT w/1 SPRING WASHER w/1 PLAIN WASHER	6	SUS304	M8X145	
12	O. RING	1	FKM	P20	
11	O. RING	1	FKM	G35	

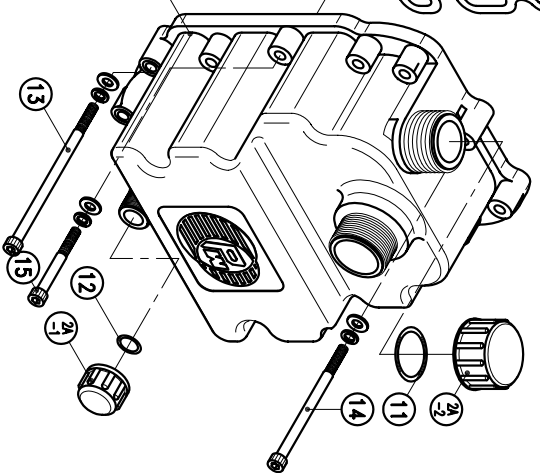
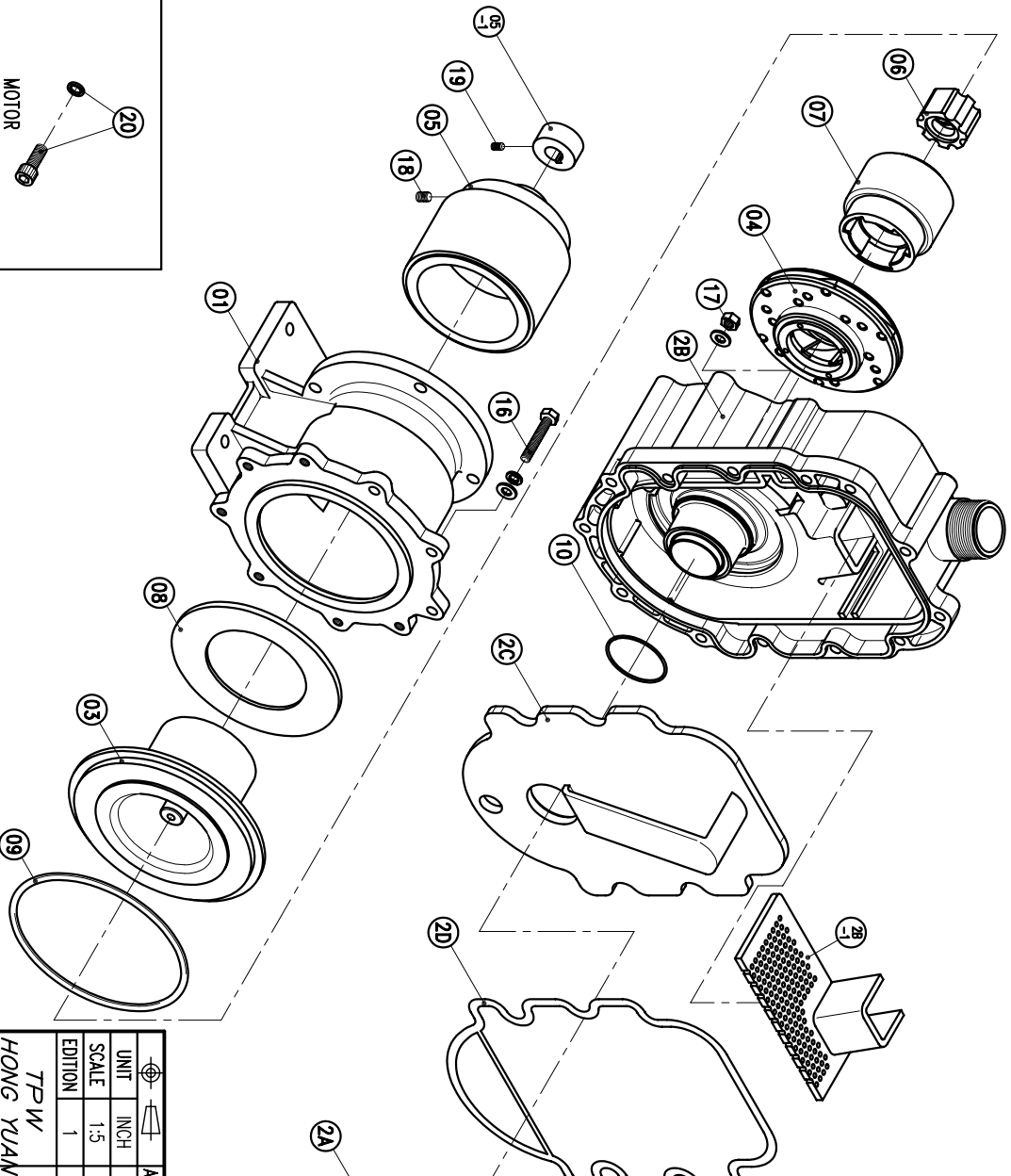

UNIT	INCH
SCALE	1-5
EDITION	1

APPROVED	
CHECK	03 17 06
DESIGN	10 22 05
DR.BY	03 17 06 BECKY

TPW
HONG YUAN

MDL NAME	NH-400PW-N-CV (NEMA)
DWG. NAME	DECOMPOSITION DRAWING
DWG. NO.	E3403629
	A3

PAN WORLD CO., LTD.
パンワールド株式会社