

NO	PART NAME	QTY	MATERIAL	NOTE	PART NO.	NO	PART NAME	QTY	MATERIAL	NOTE	PART NO.
2C	TELESCOPIC PIECE	1	PPG	286X211X68		10	O. RING	1	FKM	G30	
2B-2	FILTER	1	PPG	164X77X60		09	O. RING	1	FKM	G160	1003012301
2B-1	FLANGE	1	PPG	40A		08	BACK UP RING	1	SUS304	φ150X5.5	1003113300
2B	REAR CASING CHAMBER	1	PPG	368X226X99		07	INNER DRIVE RING	1	PPG	φ79.6X71	
2A-3	FILLER CAP	1	PPG	φ55X30		06	BEARING ASS'Y	1	CARBON	φ44X31	
2A-2	DRAIN CAP	1	PPG	φ36X24		05-1	RING	1	S45C	φ57.5X17.5	
2A-1	FLANGE	1	PPG	40A		05	OUTER DRIVE RING	1	ADC-12	φ117.5X119	1003111800
2A	FRONT CASING CHAMBER	1	PPG	342X226X152		04	IMPELLER ASS'Y	1	PPG	φ174X92.5	1003111000
02	SELF-PRIMING CHAMBER	1	PPG	FC-20		03	REAR CASING	1	PPG	φ174X92.5	1003110200
01	BRACKET	1	FC-20	φ195X145		20	GASKET	1	FKM	293X218X4.5	

21	HEXAGON SOCKET BOLT	4	SUS304	3/8" - 16X1"	
20	SET SCREW	2	S435	M6X10	
19	SET SCREW	2	S435	M8X10	
18	NUT	7	SUS304	M8	
17	HEXAGON HEAD BOLT	3	SUS304	M8X30	
16	HEXAGON SOCKET BOLT	6	SUS304	M8X70	
15	HEXAGON SOCKET BOLT	1	SUS304	M8X130	
14	HEXAGON SOCKET BOLT	6	SUS304	M8X145	
13	O. RING	1	FKM	P20	
12	O. RING	2	FKM	S40	
11	O. RING	1	FKM	G35	

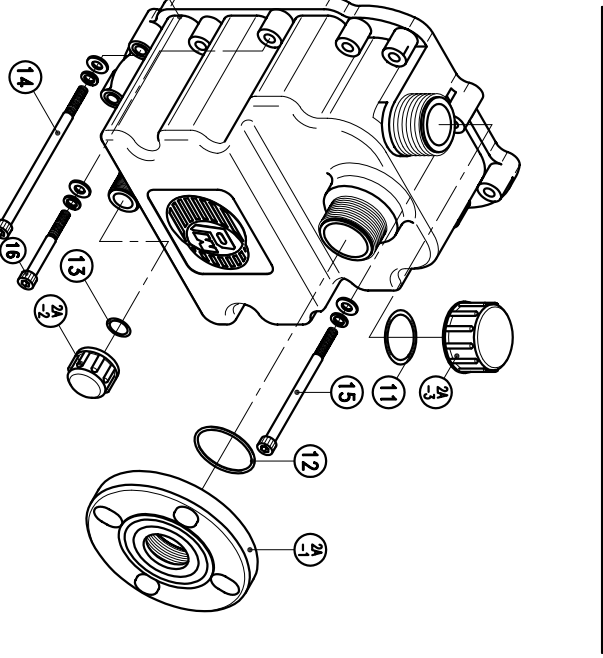
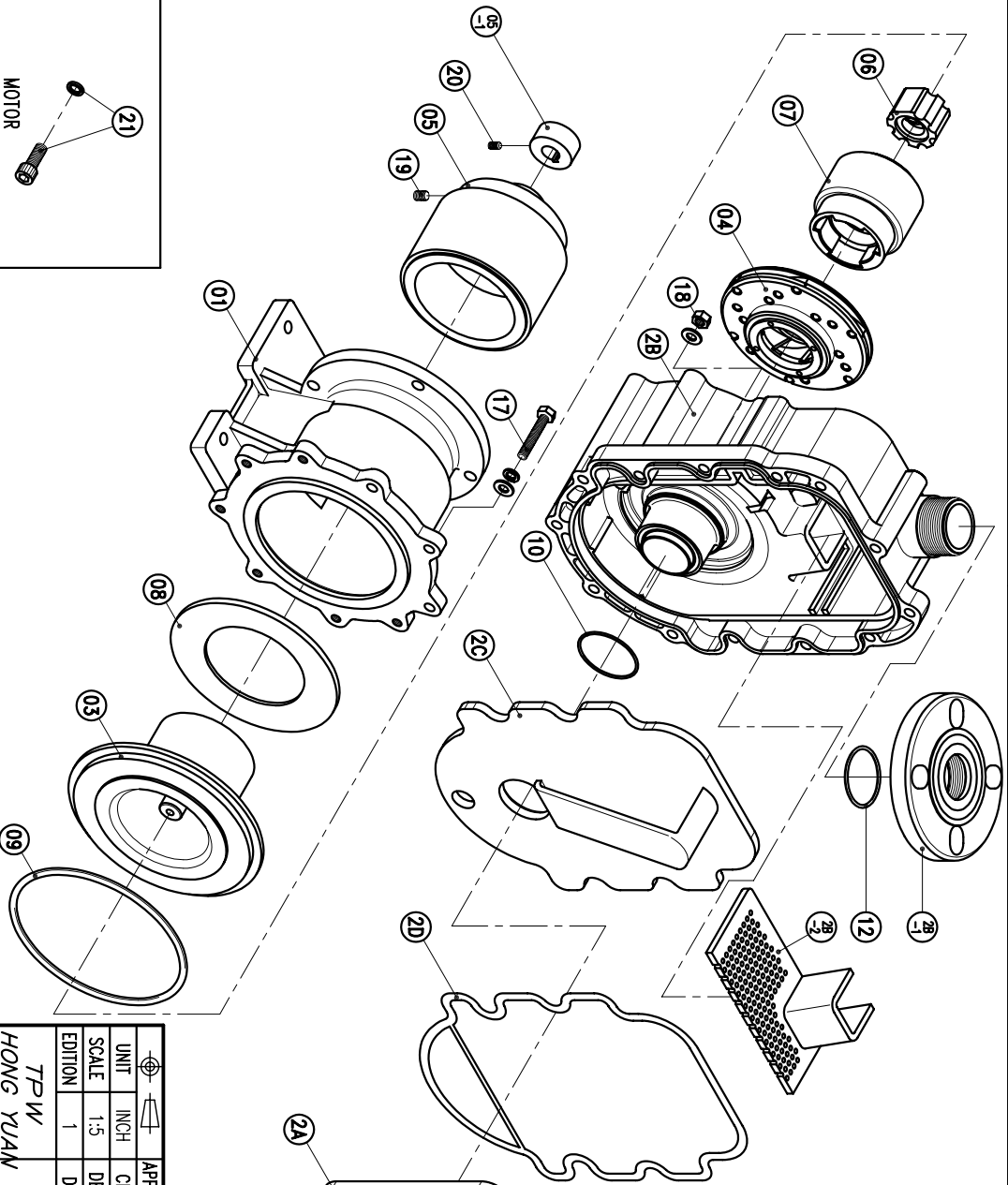

TPW	HONG YUAN
UNIT	INCH
SCALE	1:5
EDITION	1

APPROVED	03.06.06	CHECK	03.06.06	MDL. NAME	NH-400PW-N-CV (NEMA)
DESIGN	10.22.05	DR.BY	03.06.06	DWG. NAME	DECOMPOSITION DRAWING
DR.BY	03.06.06	BECKY		DWG. NO.	E3403527
					A3

PAN WORLD CO., LTD.
 パンワールド株式会社