

04-2	MOUTH RING	1	RULON	φ63X8	P2429006
04-1	IMPELLER NOUМЕНON	1	PPG	φ160X44	P2419024
04	IMPELLER ASS'Y	1	PPG		A2403784
03-4	O. RING	1	FKM	φ24.4Xφ3.1	G25
03-3	SPINDLE	1	CERAMIC	φ25X125	A2333752
03-2	REAR THRUST PAD	1	CERAMIC	φ37X8	P2329184
03-1	SPINDLE HOLDER	1	ETFE	φ41X131	
03	REAR CASING	1	PPG	φ186.5X141	A2303782
2D	GASKET	1	FKM	330.5X218X4.5	A9423724
2C	TELESCAPIC PIECE	1	PPG	323.5X211X88	A2273723
2B-5	SLEEVE	1	SUS304	φ16X90	A9123742
2B-4	SLEEVE	6	SUS304	φ16X105	
2B-3	SCREW	3	SUS304	M10X15	A9123743
2B-2	FILTER	1	PPG	164X91X75	A2273790
2B-1	THRUST PAD	1	CERAMIC	φ72X9	P2229315
2B	REAR CASING CHAMBER	1	PPG	404X226X123	A2273722
2A-3	SLEEVE	13	SUS304	φ16X38	A9123742
2A-2	FILLER CAP	1	PPG	φ55X30	A2279236
2A-1	DRAIN CAP	1	PPG	φ36X24	A2233731
2A	FRONT CASING CHAMBER	1	PPG	385X226X175	A2273774
02	SELF-PRIMING CHAMBER	1	PPG		
01	BRACKET	1	FC-20	φ208X196.5	A2123768

13	HEXAGON SOCKET BOLT	6	SUS304	M10X180		20	HEXAGON SOCKET BOLT	4	SUS304	3/8" - 16X1"	P9113080
	w/1 S.W.(M10)					19	SET SCREW	2	S435	M6X10	P9116430
	w/1 P.W.(φ21Xφ10.5X12)					18	SET SCREW	2	S435	M8X10	P9119160
12	O. RING	1	FKM	φ19.8Xφ2.4	P20	17	NUT	7	SUS304	M10	
11	O. RING	1	FKM	φ34.4Xφ3.1	G35	16	HEXAGON HEAD BOLT	3	SUS304	M10X30	
10	O. RING	1	FKM	φ59.4Xφ3.1	G60		w/1 S.W.(M10)				
09	O. RING	1	FKM	φ174.3Xφ5.7	G175		w/1 P.W.(φ21Xφ10.5X12)				
08	BACK UP RING	1	SUS304	φ164X5.5	P2119175		w/1 S.W.(M10)				
07-1	INNER MAGNET	1	Sr.FERRITE	φ76X93	P2449490		w/1 P.W.(φ21Xφ10.5X12)				
07	INNER DRIVE RING	1	PPG	φ79.6X124	A2433787		HEXAGON SOCKET BOLT				
06-1	BEARING	1	CARBON	φ56X45	P2469773	15	w/1 S.W.(M10)	6	SUS304	M10X90	
06	BEARING ASS'Y	1	ETFE	φ44X46.5	A2463761		w/1 P.W.(φ21Xφ10.5X12)				
05-1	RING	1	S45C	φ44X10	P2519340		HEXAGON SOCKET BOLT				
05	OUTER DRIVE RING	1	FCD-45	φ118X183.5	P2509335	14	w/1 S.W.(M10)	1	SUS304	M10X165	
04-3	IMPELLER COVER	1	PPG	φ160X27.8	P2459060		w/1 P.W.(φ21Xφ10.5X12)				

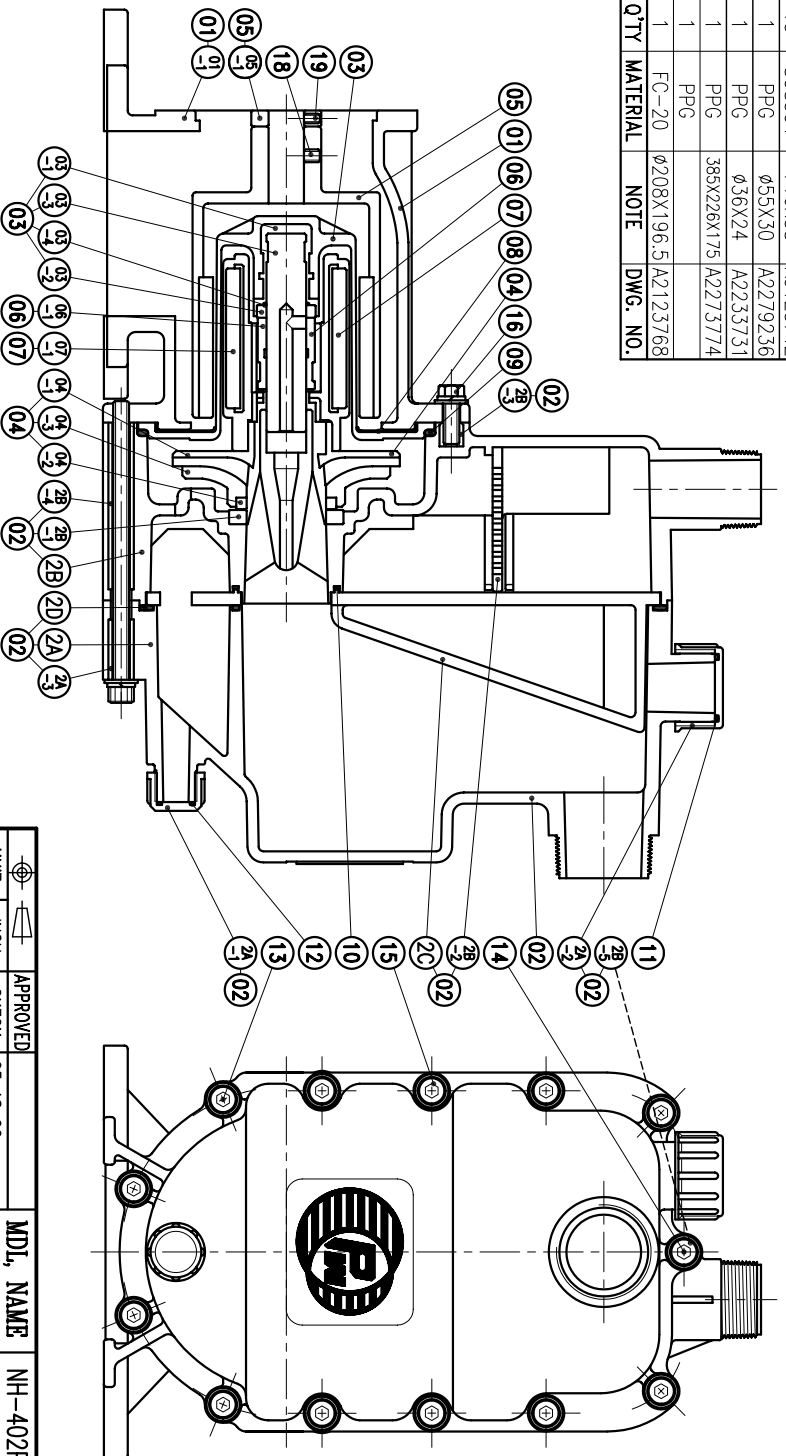

APPROVED		MDL. NAME	NH-402PW-N-CV	(NEMA)
CHECK	03 18 06	DWG. NAME	CONSTRUCTION DRAWING	
DESIGN	05 20 05	DWG. NO.	E2423626	A3
DR.BY	03 18 06 BECKY			

TPW  
HONG YUAN



PAN WORLD CO., LTD.  
パンワールド株式会社