

NO	PART NAME	QTY	MATERIAL	NOTE	PART NO.	NO	PART NAME	QTY	MATERIAL	NOTE	PART NO.				
03	REAR CASING	1	ETFE	φ240X141	1035211331	09-2	PTFE BOARD	1	PTFE	281.8X122.9	17	HEXAGON SOCKET BOLT	4	SUS304	1/2"-13x 1/4"
02-5	SLEEVE	2	SUS304	φ20X21.5		09-1	PTFE BOARD	1	PTFE	278.6X122.9	16	HEXAGON SOCKET WASHER	4	SUS304	M10X25
02-4	SLEEVE	6	SUS304	φ20X50		09	PTFE BOARD	2	PTFE	LX122.9	15	EYEBOLT	4	SUS304	M12X20
02-3	RELIEF PLATE	1	FC-20	φ261X12		08	REAR CASING COVER ASSY	1	ETFE	φ210X137	14	SET SCREW	2	S435	M8X10
02-2	FLANGE	1	ETFE	65A	1004511688	07	INNER DRIVE RING	1	ETFE	φ79.6X124	13	HEXAGON HEAD BOLT	8	SUS304	M10X110
02-1	FLANGE	1	ETFE	80A	1004511697				SIC		12	w/t SPRING WASHER	1	FKM	G55
02	FRONT CASING	1	ETFE	φ261X148	1004511691	06	BEARING	1	CERAMIC CARBON	φ44X46.5	11	w/t PLAIN WASHER	1	FKM	G85
01-1	TRANSITION FLANGE	1	FC-20	φ228.6X24.1		05	OUTER DRIVE RING	1	FCD-45	φ122X223.5	10	O. RING	1	FKM	G220
01	BRACKET	1	FC-20	φ261X208	1003013103	04	IMPELLER ASSY	1	ETFE		10	O. RING	1	FKM	G220

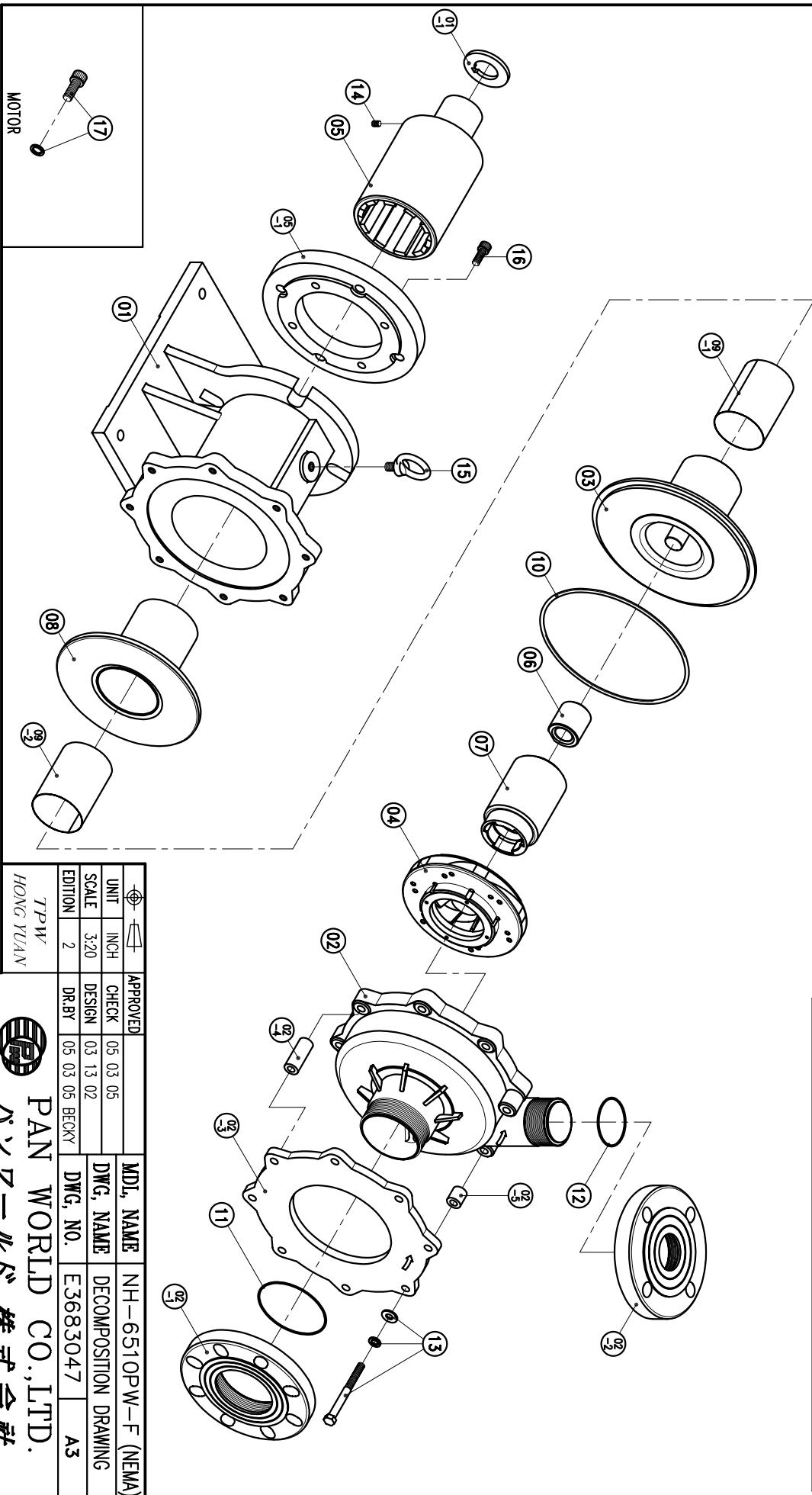

APPROVED	CHECK	SCALE	EDITION	MDL. NAME	DWG. NAME	DWG. NO.
05 03 05	03 13 02	3:20	2	NH-6510PW-F (NEMA)	DECOMPOSITION DRAWING	E3683047
TPW HONG YUAN			PAN WORLD CO., LTD. パンワールド 株式会社			