

NO	PART NAME	QTY	MATERIAL	NOTE	PART NO.
05-1	RING	1	S45C	φ44X10	
05	OUTER DRIVE RING	1	FCD-45	φ118X183.5	100331800
04	IMPELLER ASS'Y	1	ETFE		1004811314
03	REAR CASING	1	ETFE		1004710201
02	FRONT CASING	1	ETFE		1004710200
01	BRACKET	1	FC-20	φ202X186.5	1003012101

NO	PART NAME	QTY	MATERIAL	NOTE	PART NO.
14	HEAXGON SOCKET BOLT	4	SUS304	3/8" - 16X1"	
13	W/4 SPRING WASHER	1	S435	M6X10	
12	SET SCREW	2	S435	M8X10	
11	HEAXGON HEAD BOLT	5	SUS304	M10X35	
10	W/4 PLAIN WASHER	3	SUS304	M10X65	
09	O. RING	1	FKM	G175	1004711500
08	BACK UP RING	1	SUS304	φ164X5.5	1003012100
07	INNER DRIVE RING	1	ETFE	φ79.6X124	
06	BEARING ASS'Y	1	SIC CERAMIC FLUON CARBON	φ44X46.5	1004711300 1004710803 1004710802 1004711200

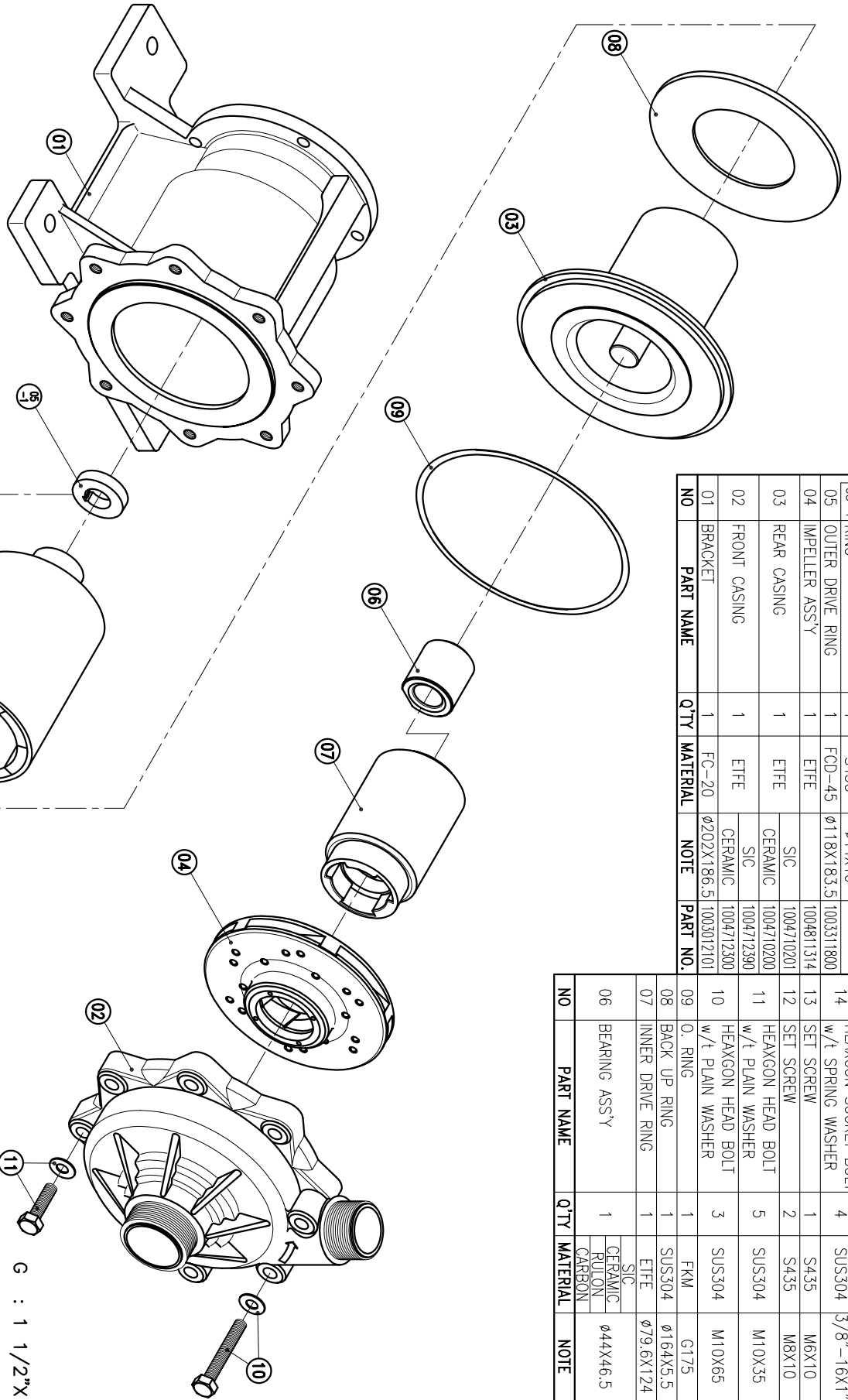

G : 1 1/2" X 2"
NPT : 1 1/2" X 2"

APPROVED	CHECK	MDL NAME	DECOMPOSITION DRAWING
09 01 03	03 14 97	NH-403PW-F(NEMA)	
09 01 03 BECKY		DWG. NAME	
		DWG. NO.	E3435050
			A3

TPW
HONGYUAN



PAN WORLD CO., LTD.
パンワールド株式会社