

NO	PART NAME	Q'TY	MATERIAL	NOTE	DWG. NO.
03-2	REAR THRUST PAD	1	SIC		P2329188
			CERAMIC	φ37X8	P2329184
03-1	SPINDLE HOLDER	1	ETFE	φ41X131	P2379483
03	REAR CASING	1	ETFE	φ240X141	P2304738
02-6	SLEEVE	2	SUS304	φ20X21.5	A2273365
02-5	SLEEVE	6	SUS304	φ20X50	A2273365
02-4	RELIEF PLATE	1	FC-20	φ261X12	A2273364
02-3	FLANGE	1	ETFE	65A	P2233892
02-2	FLANGE	1	ETFE	80A	P2233893
02-1	FRONT THRUST PAD	1	SIC		P2224475
			CERAMIC	φ104X9	A2203366
01-1	FRANSTION FLANGE	1	ETFE	φ261X148	PP2179308
01	BRACKET	1	FC-20	φ261X208	A2123378
08-1	BACK UP RING	1	SUS304	φ210X8.5	A2119285
08	REAR CASING COVER ASS'Y	1		φ210X137	P2114731
07-1	INNER MAGNET	1	Nd-Fe-B	φ76X93	P2449491
07	INNER DRIVE RING	1	ETFE	φ79.6X124	P2439018
06-1	BEARING	1	SIC		P2469772
			CERAMIC	φ36X45	P2469183
			CARBON		P2469773
06	BEARING ASS'Y	1	ETFE	φ44X46.5	A2469553
05-1	RING	1	S45C	φ65X5.7	P2574346
05	OUTER DRIVE RING	1	FCD-45	φ122X223.5	P2504344
04-3	IMPELLER COVER	1	ETFE	φ175X20	P2454028
04-2	MOUTH RING	1	RULON	φ104X9	P2424412
04-1	IMPELLER NOLMENNON	1	ETFE	φ175X44	P2414022
04	IMPELLER ASS'Y	1	ETFE		A2403119
03-4	O. RING	1	FKM	φ24.4Xφ3.1	G25
03-3	SPINDLE	1	SIC		P2339005
			CERAMIC	φ25X125	
17	HEXAGON SOCKET BOLT	4	SUS304	1/2"-13x1 1/4"	A9119381
16	HEXAGON SOCKET BOLT	4	SUS304	w/t S.W. (1/2") (MOTOR)	
15	EYEBOLT	1	S41C	M12X20	P9114152
14	SET SCREW	2	S435	M8X10	P9119160
13	HEXAGON HEAD BOLT	8	SUS304	w/t S.W. (M10)	
				w/t P.W. (φ22Xφ10X12)	P9113080
12	O. RING	1	FKM	φ54.4Xφ3.1	G55
11	O. RING	1	FKM	φ84.4Xφ3.1	G85
10	O. RING	1	FKM	φ219.3Xφ5.7	G220
09-2	PTFE BOARD	1	PTFE	281.8X122.9	A2119713
09-1	PTFE BOARD	1	PTFE	278.6X122.9	A2119713
09	PTFE BOARD	2	PTFE	LX122.9	A2119713
08-3	COVER	1	SUS304	φ90.4X112	A2119715
08-2	PIPE	1	HASTELLOY C	φ690.4X133.5	A2119712

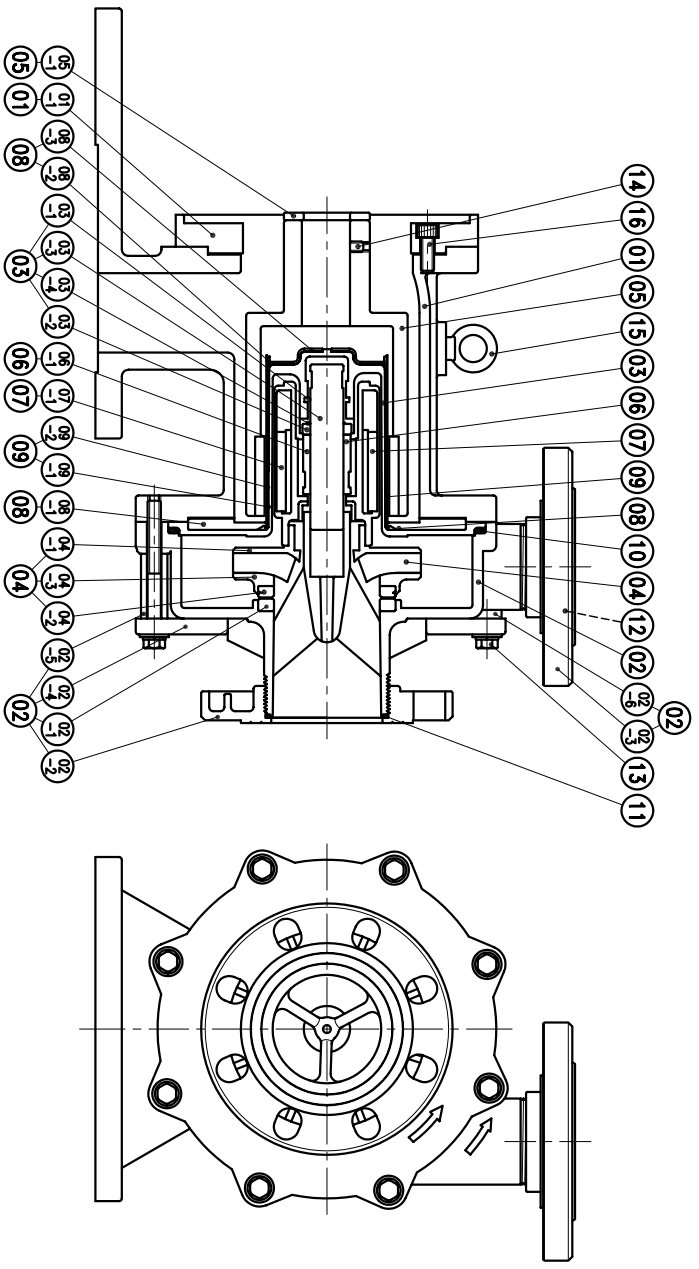

APPROVED	05 03 05	MDL NAME	NH-657PW-F (NEMA)
CHECK	02 18 00	DWG. NAME	CONSTRUCTION DRAWING
DESIGN	05 03 05	DWG. NO.	E2673087
DR.BY			A3

  
**PAN WORLD CO., LTD.**  
 パンワールド株式会社