

03-2	REAR THRUST PAD	1	CERAMIC	037X8	P2329188	06-1	BEARING	1	SIC	036X45	P2489172	14	HEXAGON SOCKET BOLT w/1 S.W.(3/8") (MOTOR)	4	SUS304	3/8"-16X1"	A9119380
03-1	SPINDLE HOLDER	1	ETFE	041X131	P2329184	06	BEARING ASS'Y	1	CERAMIC CARBON RULON	044X46.5	P2489185 P2489183 P2489173 A2489348	13	SET SCREW	1	S435	M6X10	P9116430
03	REAR CASING	1	ETFE	0186.5X141	P2309178	05-1	RING	1	S45C	044X10	P2579340	12	SET SCREW	2	S435	M8X10	P9119160
02-1	FRONT THRUST PAD	1	SIC	072X9	P2229315	05	OUTER DRIVE RING	1	FCD-45	0118X183.5	P2509335	11	HEXAGON HEAD BOLT w/1 P.W.(021X010.5X12)	5	SUS304	M10X35	P9113080
02	FRONT CASING	1	CERAMIC	0202X113	P2203180	04-2	IMPELLER COVER	1	ETFE	0160X27.8	P2459060	10	HEXAGON HEAD BOLT w/1 P.W.(021X010.5X12)	3	SUS304	M10X65	P9113080
01	BRACKET	1	ETFE	0202X196.5	A2123148	04-1	IMPELLER NOUWENON	1	ETFE	0160X44	P2419024	09	O. RING	1	FKM	0174.3X05.7	G175
			FC-20	0202X196.5	A2123148	04	IMPELLER ASS'Y	1	ETFE		P2409177	08	BACK UP RING	1	SUS304	0164X5.5	P2119175
						03-4	O. RING	1	FKM	024.4X03.1	G25	07	INNER DRIVE RING	1	Sr-FERRITE	076X9.3	P2449490
						03-3	SPINDLE	1	CERAMIC	025X125	P2339005	07	INNER DRIVE RING	1	ETFE	079.6X124	P2439018

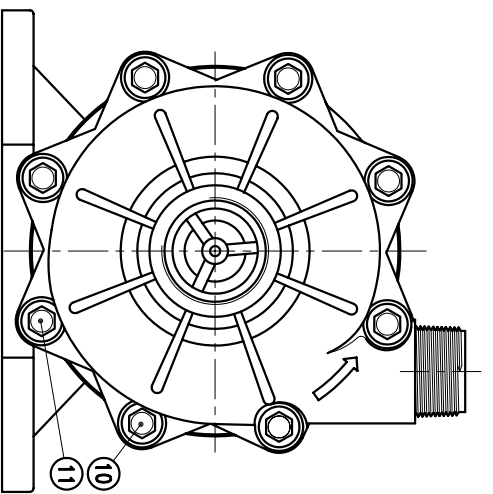
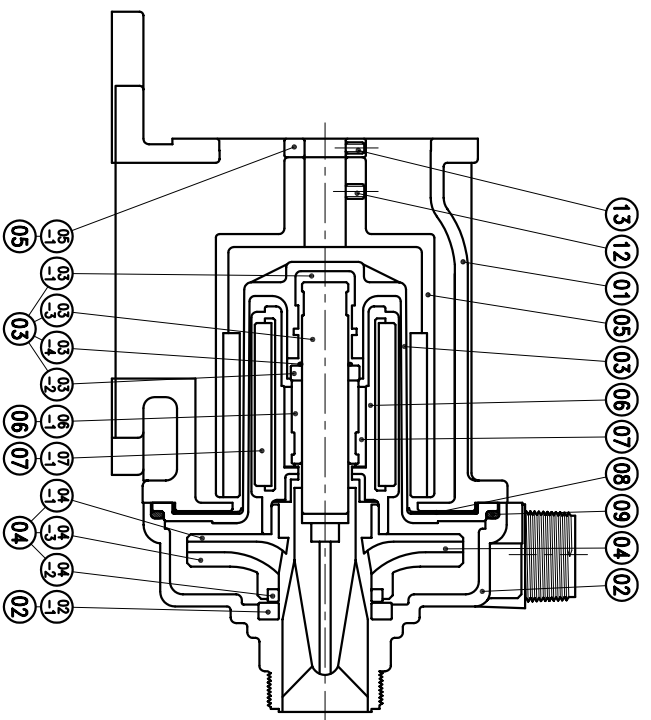

G : 1 1/2" X 2"
NPT : 1 1/2" X 2"

APPROVED	CHECK	02 16 04	MDL NAME	NH-402PW-F (NEMA)
SCALE	DESIGN	10 23 96	DWG. NAME	CONSTRUCTION DRAWING
EDITION	DRBY	02 16 04 BECKY	DWG. NO.	E2423092
				A3

TPW
HONG YUAN

PAN WORLD CO., LTD.
パンワールド株式会社