

03-2	REAR THRUST PAD	1	SIC	037X8	P2329188	06-1	BEARING	1	SIC	036X45	P2489172	16	HEXAGON SOCKET BOLT	4	SUS304	3/8" - 16X1"	A9119380
			CERAMIC		P2329184				CERAMIC CARBON RULON		P2489185 P2489183 P2489173 A2489348		w/1 S.W.(3/8") (MOTOR)				
03-1	SPINDLE HOLDER	1	ETFE	041X131	P2379483	06	BEARING ASS'Y	1	ETFE	044X46.5	A2469553	15	SET SCREW	1	S435	M6X10	P9116430
03	REAR CASING	1	ETFE	0186.5X141	P2309178	05-1	RING	1	S45C	044X10	P2579340	14	SET SCREW	2	S435	M8X10	P9119160
02-3	FLANGE	1	ETFE	40A	P2233172	05	OUTER DRIVE RING	1	FOD-45	0118X183.5	P2509335	13	HEXAGON HEAD BOLT	5	SUS304	M10X35	P9113080
02-2	FLANGE	1	ETFE	50A	P2233411	04-3	IMPELLER COVER	1	ETFE	0160X27.8	P2459060	12	w/1 P.W.(021X010.5X12)				
02-1	FRONT THRUST PAD	1	SIC	072X9	P2229315	04-2	MOUTH RING	1	RULON	063X8	P2429006	11	HEXAGON HEAD BOLT	3	SUS304	M10X65	P9113080
			CERAMIC			04-1	IMPELLER NOUМЕНON	1	ETFE	0160X44	P2419024	10	w/1 P.W.(021X010.5X12)				
02	FRONT CASING	1	ETFE	0202X113	P2203180	04	IMPELLER ASS'Y	1	ETFE		P2409177	09	O. RING	1	FKM	044.4X03.1	G45
01	BRACKET	1	FC-20	0202X196.5	A2123148	03-4	O. RING	1	FKM	024.4X03.1	G25	10	O. RING	1	FKM	049.4X03.1	G50
						03-3	SPINDLE		CERAMIC	025X125	P2339005	08	BACK UP RING	1	SUS304	0164X5.5	P2119175
												07	INNER DRIVE RING	1	Sr-FERRITE	076X9.3	P2449490

NO	PART NAME	Q'TY	MATERIAL	NOTE	DWG. NO.
07	INNER DRIVE RING	1	ETFE	079.6X124	P2439018

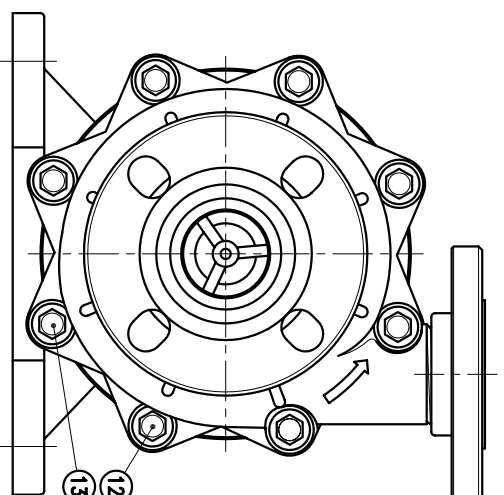
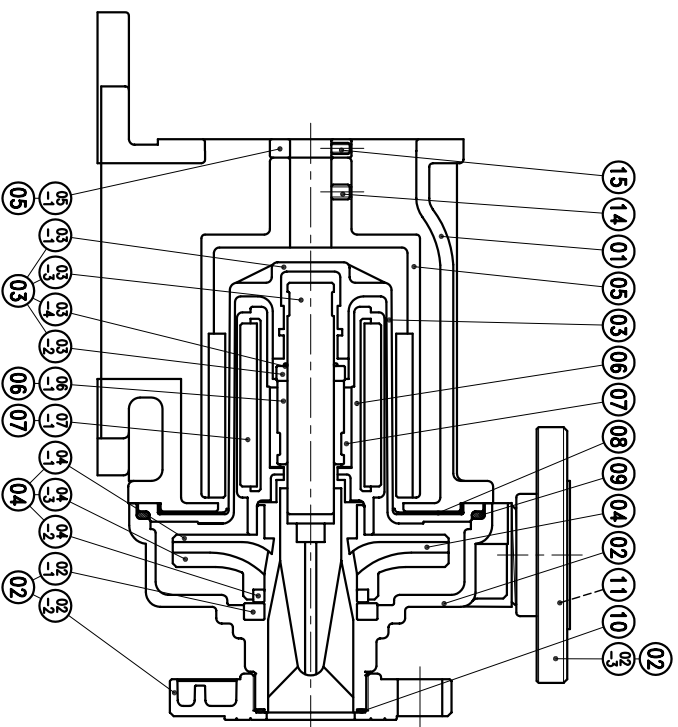

APPROVED	CHECK	02 16 04	MDL NAME	NH-402PW-F (NEMA)
DESIGN	DESIGN	10 23 96	DWG. NAME	CONSTRUCTION DRAWING
DR.BY	DR.BY	02 12 04 BECKY	DWG. NO.	E2423083
EDITION		4		A3

TPW
HONG YUAN



PAN WORLD CO., LTD.
パンワールド株式会社