

NO	PART NAME	QTY	MATERIAL	NOTE	DWG. NO.	NO	PART NAME	QTY	MATERIAL	NOTE	DWG. NO.
03-3	SPINDLE	1	SIC	020X65	P2339096	07	INNER DRIVE RING	1	ETFE	079.6X71	P2439077
			CERAMIC						SIC		P2469100
03-2	REAR THRUST PAD	1	SIC	036X6.5	P2329095	06-1	BEARING	1	CERAMIC	032X28	P2469270
			CERAMIC						ALUM		P2469177
03-1	SPINDLE HOLDER	1	ETFE	040X68	P2379093	06	BEARING ASS'Y	1	ETFE	044X31	P2469076
03	REAR CASING	1	ETFE	0164X92.5	P2309073	05-1	RING	1	S45C	057.5X17.5	P2379332
02-2	FLANGE	2	ETFE	40A	P2233172	05	OUTER DRIVE RING	1	ADC-12	0117.5X117	P2509330
			SIC			04-3	IMPELLER COVER	1	ETFE	0105X18	P2459099
02-1	FRONT THRUST PAD	1	ETFE	058X8.5	P2229092	04-2	MOUTH RING	1	RULON	052X7	P2429098
			CERAMIC			04-1	IMPELLER NOLUENON	1	ETFE	0105X30	P2419097
02	FRONT CASING	1	ETFE	0174X110	P2203102	04	IMPELLER ASS'Y	1	ETFE	0105X30	P2409074
01	BRACKET	1	FC-20	0174X140.4	A2123146	03-4	RING	1	FKM	019.8X02.4	P20
						10	RING	2	FKM	044.3X03.1	G45
						09	RING	1	FKM	0149.3X05.7	G150
						08	BACK UP RING	1	SUS304	0140X5.5	P2119089
						07-1	INNER MAGNET	1	FERRITE	076X44.5	P2449101
						15	HEXAGON SOCKET BOLT	4	SUS304	3/8"-16X1" A9119380	
							w/1 S.W.(3/8") (MOTOR)				
						14	SET SCREW	1	S435	M6X10	P9116430
						13	SET SCREW	2	S435	M8X10	P9119160
						12	HEXAGON HEAD BOLT	5	SUS304	M8X30	P9113079
							w/1 P.W.(017X08.4X11.6)				
						11	HEXAGON HEAD BOLT	1	SUS304	M8X55	P9113079
							w/1 P.W.(017X08.4X11.6)				

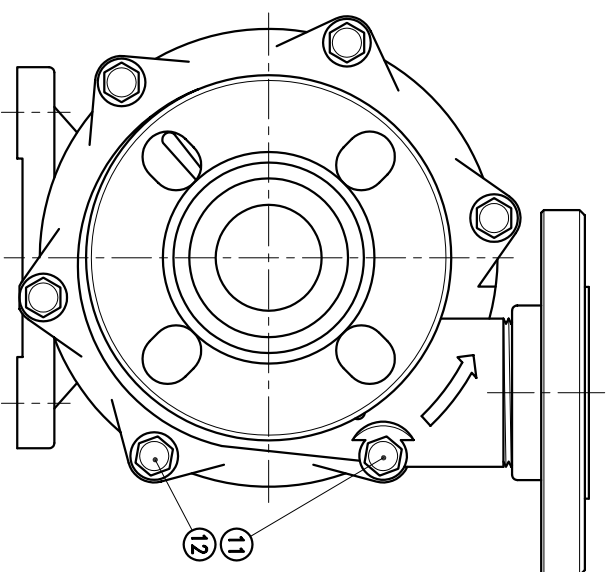

APPROVED	MDL NAME	NH-400PW-F (NEMA)
CHECK	DWG. NAME	CONSTRUCTION DRAWING
DESIGN	DWG. NO.	E2403081
DR.BY	EDITION	A3
04 02 05 BECKY	3	

TPW  
HONG YUAN

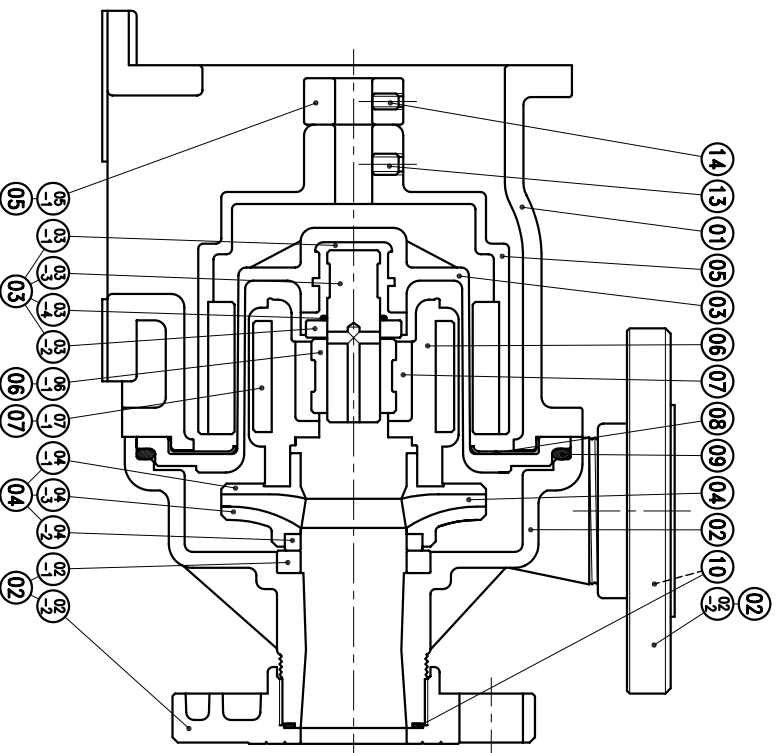

PAN WORLD CO., LTD.  
パンワールド株式会社