

NO	PART NAME	Q'TY	MATERIAL	NOTE	PART NO.
01-3	COVER C	1	FC-20	φ153X45	
01-2	COVER B	1	FC-20	φ127X23	100571800
01-1	COVER A	1	FC-20	φ210X59.5	
01	BRACKET	1	FC-20	φ210X186.5	1004519102

NO	PART NAME	Q'TY	MATERIAL	NOTE	PART NO.
07	INNER DRIVE RING	1	ETFE	φ79.6X124	
06	BEARING ASS'Y	1	SIC		1004711300
			CERAMIC		1004710803
			PULON	φ44X46.5	1004710802
			CARBON		1004711200
05-1	RING	1	S45C	φ44X10	
05	OUTER DRIVE RING	1	FCD-45	φ118X183.5	1003211800
04	IMPELLER ASS'Y	1	ETFE		1004711314
03	REAR CASING	1	ETFE		1004710201
02	FRONT CASING	1	ETFE		1005711390
			CERAMIC		1005711300
01-4	TRANSITION FLANGE	1	FC-20	φ165.1X14	

NO	PART NAME	Q'TY	MATERIAL	NOTE	PART NO.
18	HEXAGON SOCKET BOLT w/t SPRING WASHER	4	SUS304	3/8"-16X1"	
17	COUNTER SUNK HEAD BOLT	4	S435	M10X20	
16	SET SCREW	2	S435	M6X10	
15	SET SCREW	2	S435	M8X10	
14	HEXAGON SOCKET BOLT	3	SUS304	M6X20	
13	HEXAGON SOCKET BOLT	2	SUS304	M6X16	
12	HEXAGON SOCKET BOLT	4	SUS304	M8X16	
11	HEXAGON SOCKET BOLT w/t SPRING WASHER	7	SUS304	M8X40	
10	HEXAGON SOCKET BOLT w/t SPRING WASHER	1	SUS304	M8X60	
09	O. RING	1	FKM	G175	1004711500
08	BACK UP RING	1	SUS304	φ164X5.5	1003013300

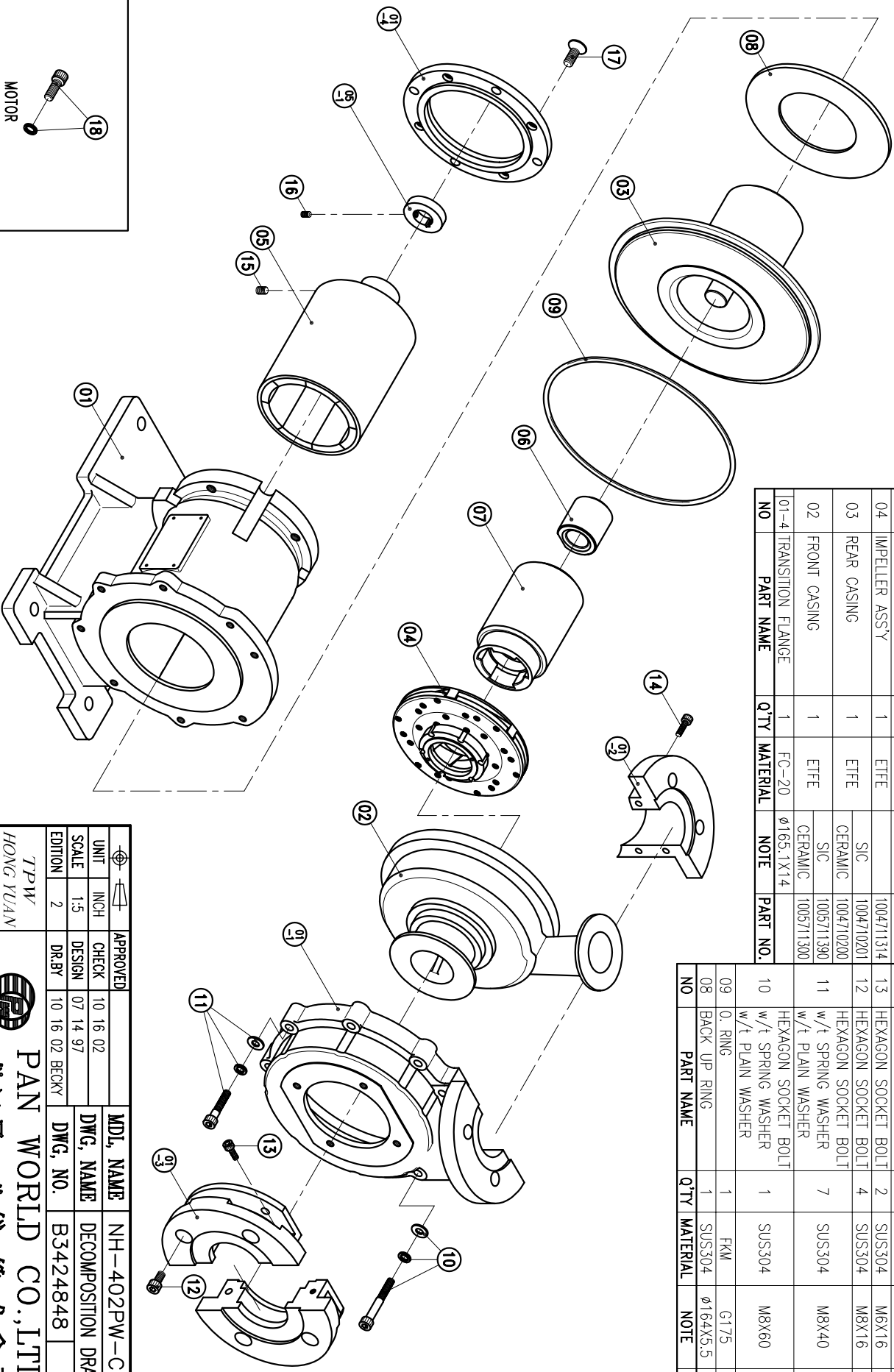

UNIT	INCH	CHECK	APPROVED	MDL. NAME	NH-402PW-C (NEMA)
SCALE	1:5	DESIGN	07 14 97	DWG. NAME	DECOMPOSITION DRAWING
EDITION	2	DR.BY	10 16 02 BECKY	DWG. NO.	B3424848
					A3

TPW  
HONG YUAN

PAN WORLD CO., LTD.  
パンワールド株式会社

