

03-4	O. RING	1	FKM	φ24.4Xφ3.1	G25	08-3	COVER	1	SUS304	φ90.4X12	A2119715	19	HEXAGON SOCKET BOLT	4	SUS304	1/2"-13x1 1/4"				
03-3	SPINDLE	1	SIC	φ25X125	P2339005	08-2	PIPE	1	HASTELLOY C	φ90.4X127.5	A2119716	18	HEXAGON SOCKET BOLT	4	SUS304	M10X25				
03-2	REAR THRUST PAD	1	SIC	φ37X8	P2329188	08-1	BACK UP RING	1	SUS304	φ162X5.5	A2119714	17	HEXAGON SOCKET BOLT	1	S41C	M12				
03-1	SPINDLE HOLDER	1	CERAMIC	φ37X8	P2329184	07-1	INNER MAGNET	1	Nd-Fe-B	φ76X93	P2444185	16	SET SCREW	2	S435	M8X10				
03	REAR CASING	1	ETFE	φ41X131	P2379483	07	INNER DRIVE RING	1	ETFE	φ79.6X124	P2439018	15	HEXAGON SOCKET BOLT	3	SUS304	M6X20				
02-1	FRONT THRUST PAD	1	ETFE	φ186.5X141	P2309737	06-1	BEARING	1	SIC		P2469772	14	HEXAGON SOCKET BOLT	2	SUS304	M6X16				
02	FRONT CASING	1	SIC	φ88X9	P2224476				CERAMIC	φ36X45	P2469773	13	HEXAGON SOCKET BOLT	4	SUS304	M8X20				
02	FRONT CASING	1	CERAMIC	φ88X9	P2224476				CARBON RULON		A2469348	12	HEXAGON SOCKET BOLT	7	SUS304	M10X50				
01-4	TRANSITION FLANGE	1	ETFE	φ200X143	P2214740	06	BEARING ASS'Y	1	ETFE	φ44X46.5	A2469553	11	HEXAGON SOCKET BOLT	1	SUS304	M10X85				
01-3	COVER C	1	FC-20	φ228.6X29.1	P2179308	05-1	RING	1	S45C	φ65X5.7	P2574346	10	W/t S.W. (M10)	1	SUS304					
01-2	COVER B	1	FC-20	φ185X66.5	P2154032	05	OUTER DRIVE RING	1	FCD-45	φ122X223.5	P2504344	10	O. RING	1	FKM	φ174.3Xφ5.7				
01-1	COVER A	1	FC-20	φ165X23	P2144139	04-3	IMPELLER COVER	1	ETFE	φ175X20	P2454027	10	O. RING	1	FKM	φ174.3Xφ5.7				
01	BRACKET	1	FC-20	φ215X73	P2134140	04-2	MOUTH RING	1	RULON	φ82X8	P2424056	09	PTFE BOARD	1	PTFE	281.8X122.9				
NO	PART NAME	Q'TY	MATERIAL	NOTE	DWG. NO.	NO	PART NAME	Q'TY	MATERIAL	NOTE	DWG. NO.	NO	PART NAME	Q'TY	MATERIAL	NOTE	DWG. NO.			
						04	IMPELLER ASS'Y	1	ETFE	φ175X44	P2414022	09	PTFE BOARD	2	PTFE	L X 122.9				

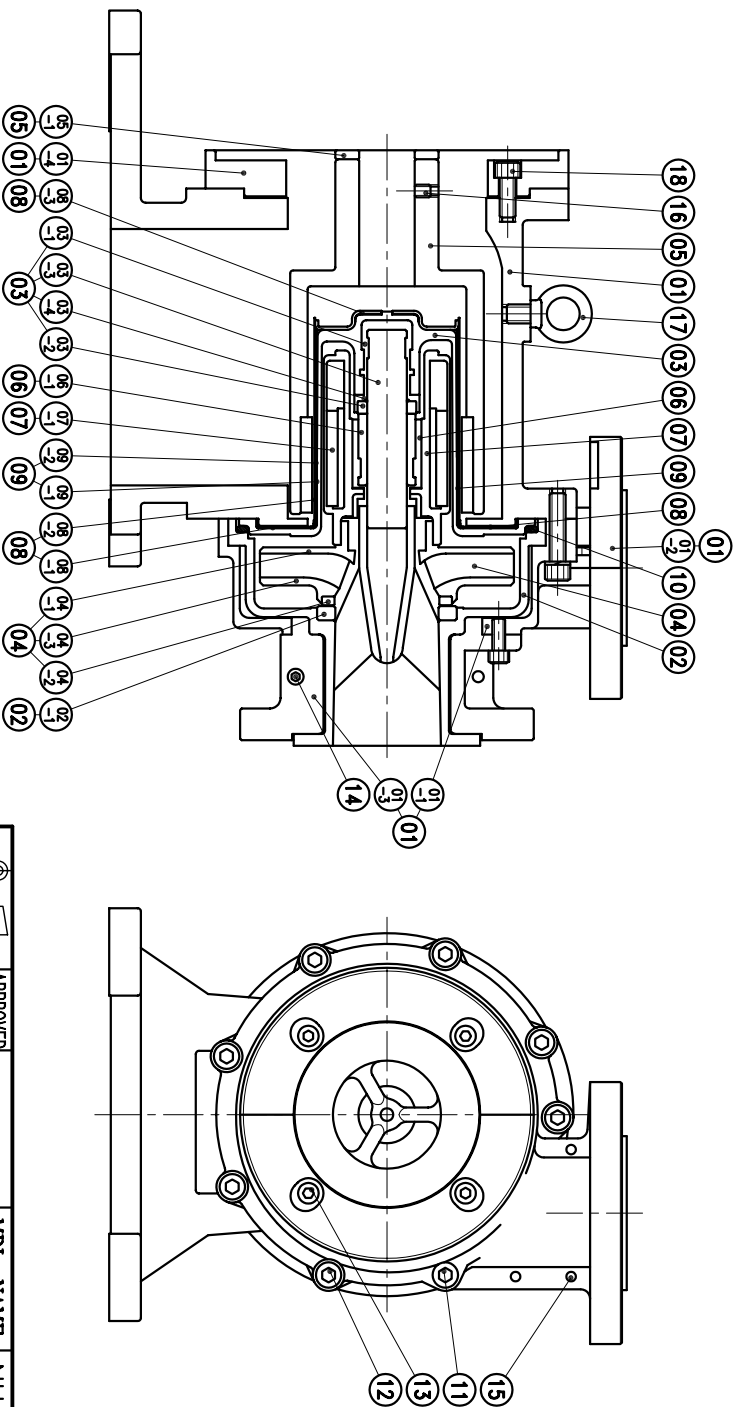

APPROVED		MDL. NAME	NH-507PW-C (NEMA)
CHECK	05.03.05	DWG. NAME	CONSTRUCTION DRAWING
DESIGN	01.11.02	DWG. NO.	B2574733
DR.BY	05.03.05 BECKY		A3

TPW
HONG YUAN



PAN WORLD CO., LTD.
パンワールド株式会社