

NO	PART NAME	Q'TY	MATERIAL	NOTE	DWG. NO.	NO	PART NAME	Q'TY	MATERIAL	NOTE	DWG. NO.	NO	PART NAME	Q'TY	MATERIAL	NOTE	DWG. NO.	
04	IMPELLER ASS'Y	1	ETFE		P2404019	09	PTFE BOARD	2	PTFE	L X 122.9 A2119713		20	HEXAGON SOCKET BOLT	4	SUS304	1/2" - 13X1"		
03-4	O. RING	1	FKM	φ24.4Xφ3.1	G25	08-3	COVER	1	SUS304	φ90.4X12 A2119715		19	w/t S.W.(1/2")(MOTOR)	4	S435	M10X25	P9119375	
03-3	SPINDLE	1	SIC	φ25X125	P2339005	08-2	PIPE	1	HASTELLOY	φ90.4X127.5A2119716		18	COUNTER SUNK HEAD BOLT	1	S41C	M12	P9114152	
03-2	REAR THRUST PAD	1	CERAMIC	φ37X8	P2329188	08-1	BACK UP RING	1	SUS304	φ164X5.5 A2119714		17	EYE BOLT	2	S435	M6X10	P9116430	
03-1	SPINDLE HOLDER	1	CERAMIC	φ37X8	P2329188	08	REAR CASING COVER	1	Nd-Fe-B	φ164X137 A2119717		16	SET SCREW	2	S435	M8X10	P9119160	
03	REAR CASING	1	ETFE	φ41X131	P2379483	07	INNER DRIVE RING	1	ETFE	φ76X93 P2449491		15	HEXAGON SOCKET BOLT	3	SUS304	M6X20	P9119156	
02-1	FRONT THRUST PAD	1	SIC	φ186.5X140	P2309737	06-1	BEARING	1	CERAMIC CARBON RULON	φ79.6X124 P2439018		14	HEXAGON SOCKET BOLT	2	SUS304	M6X16	P9119156	
02	FRONT CASING	1	CERAMIC	φ88X9	P2224476	06	BEARING ASS'Y	1	ETFE	φ36X45 P2469183 P2469173 A2469348		13	HEXAGON SOCKET BOLT	4	SUS304	M8X20	P9119155	
01-4	TRANSITION FLANGE	1	ETFE	φ200X143	P2214740	05-1	RING	1	ETFE	φ44X46.5 A2469553		12	HEXAGON SOCKET BOLT	7	SUS304	M10X50	P9119155	
01-3	COVER C	1	FC-20	φ228.6X18	P2179307	05	OUTER DRIVE RING	1	S45C	φ48X9.8 P2509342		11	HEXAGON SOCKET BOLT	1	SUS304	M10X85	P9119155	
01-2	COVER B	1	FC-20	φ185X66.5	P2154032	04-3	IMPELLER COVER	1	FCD-45	φ122X205 P2509341		10	w/t S.W.(M10)	1	FKM	φ174.3Xφ5.7	G175	
01-1	COVER A	1	FC-20	φ165X23	P2144139	04-2	MOULTH RING	1	ETFE	φ175X20 P2454027		09-2	PTFE BOARD	1	PTFE	281.8X122.9A2119713		
01	BRACKET	1	FC-20	φ215X73	P2134140	04-1	IMPELLER NOUMENON	1	RULON	φ82X8 P2424056		09-1	PTFE BOARD	1	PTFE	278.6X122.9A2119713		
					A2124006					φ175X44 P2414022								

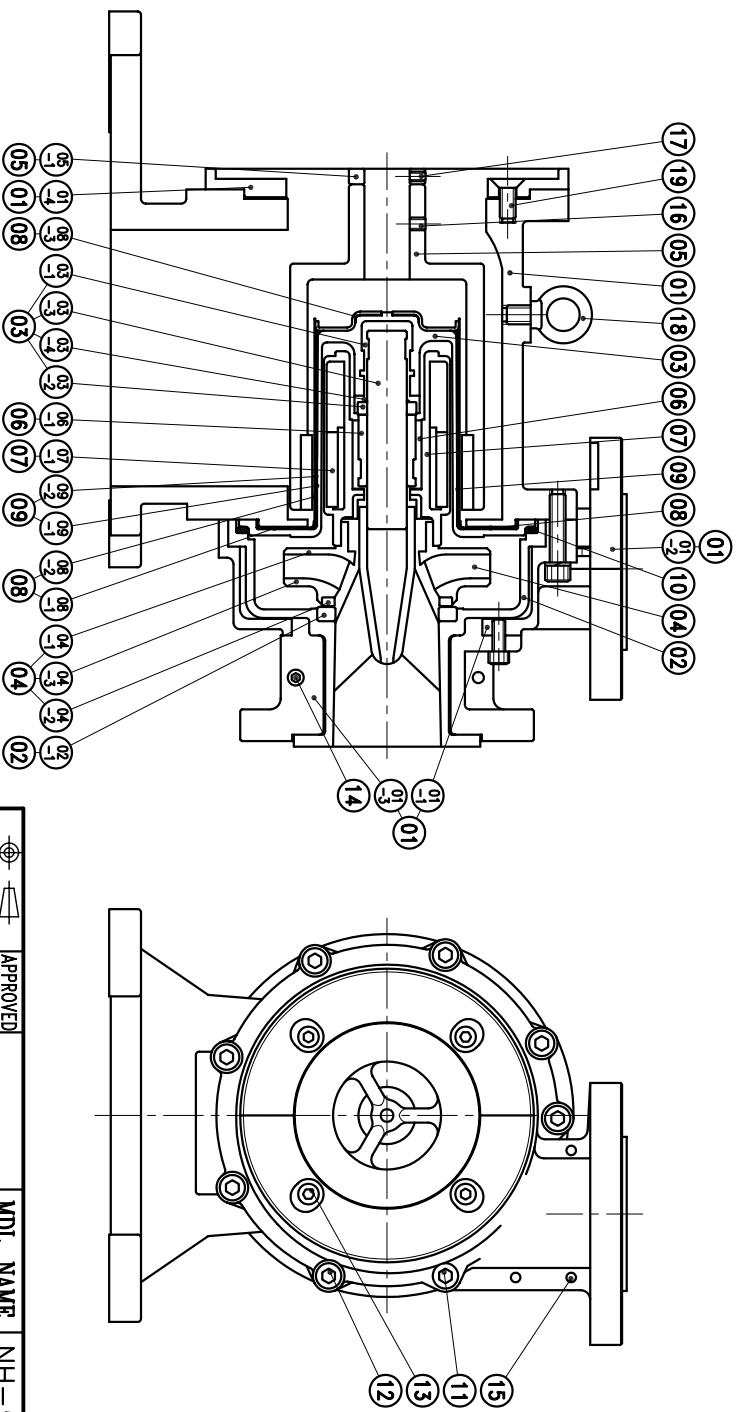

APPROVED	CHECK	DESIGN	DR.BY	EDITION	MDL NAME	DWG. NAME	DWG. NO.
	05 03 05	01 11 02	05 03 05	3	NH-505PW-C (NEMA)	CONSTRUCTION DRAWING	B2554570
					A3		

TPW
HONG YUAN



PAN WORLD CO., LTD.
パンワールド株式会社