

NO	PART NAME	QTY	MATERIAL	NOTE	PART NO.
02-1	FLANGE	2	PPG	25A	1001007100
02	FRONT CASING	1	PPG	φ123.5X87.5	1001006100
01	MOTOR	1	90W , 2P , 3φ		

11	SET SCREW	2	S435	M6X10	
10	HEXAGON HEAD BOLT w/t PLAIN WASHER	6	SUS304	M6X55	
09	O. RING	2	FKM	P20	1001301300
08	O. RING	1	FKM	G110	1001001300
07	BACK UP RING	1	SUS304	φ98X4.5	1001008600
06	BEARING	1	CERAMIC CARBON	φ25X35	1001000900
05	OUTER DRIVE RING	1	ADC-12	φ86X86	1003411800
04	IMPELLER ASS'Y	1	PPG		
03	REAR CASING	1	PPS	φ123.5X75	1001000500

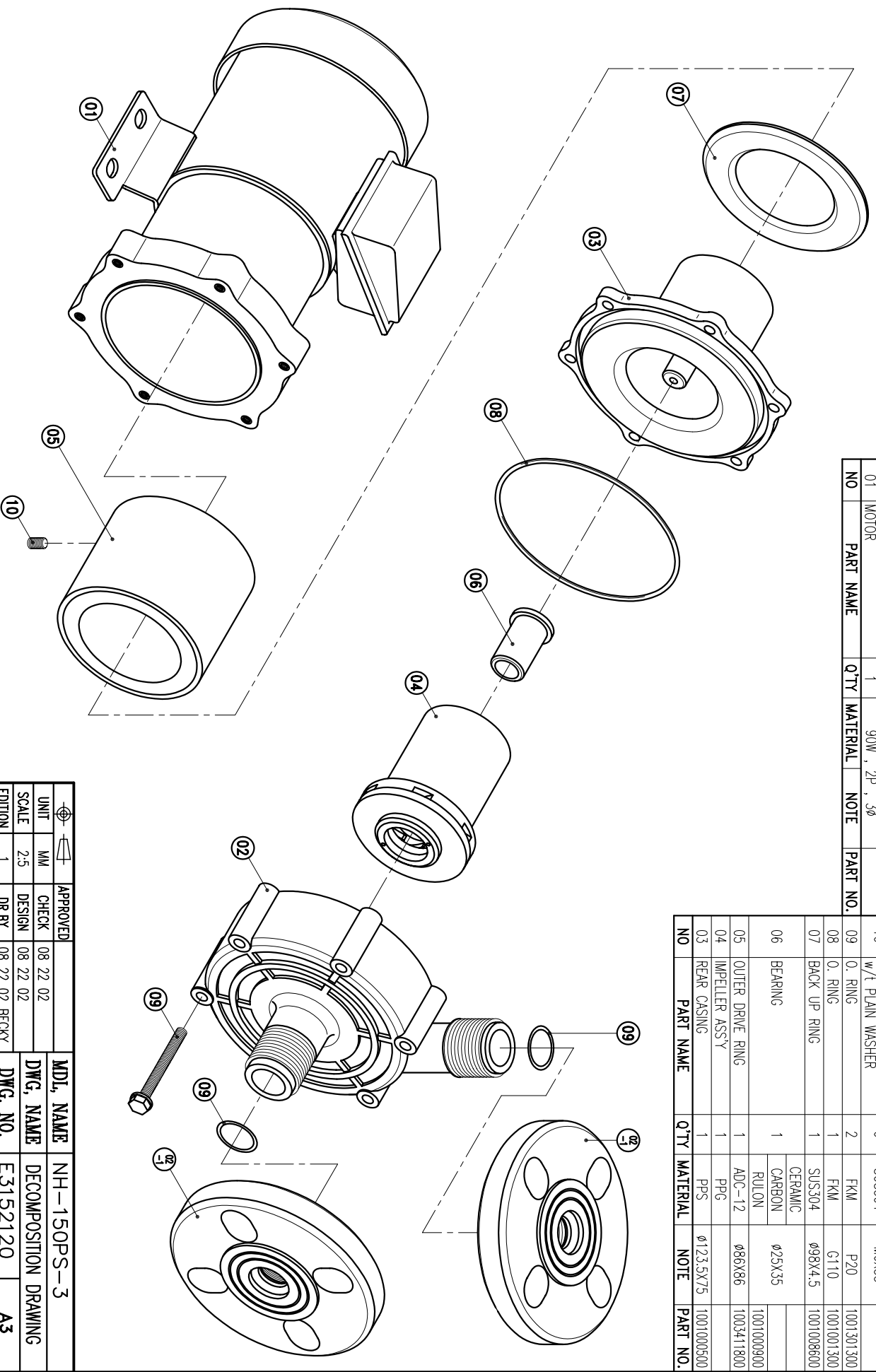

APPROVED	CHECK	DATE	MDL NAME	NH-150PS-3
		08 22 02	DWG, NAME	DECOMPOSITION DRAWING
		08 22 02	DWG, NO.	E3152120
		08 22 02	DR.BY	BECKY
			EDITION	1
			SCALE	2.5
			UNIT	MM

TPW
HONG YUAN



PAN WORLD CO., LTD.
パンワールド株式会社