

03-2	SPINDLE	1	CERAMIC	φ14X60	P2332110	05-1	MAGNET HOUSING	1	ADC-12	φ68X86	P2512114	10	SET SCREW	2	S435	M6X10	P9116430
03-1	REAR THRUST PAD	1	CERAMIC	φ23X4	P2322109	05	OUTER DRIVE RING	1	φ68X86	P2509064	09	HEXAGON HEAD BOLT w/L P.W.(φ10Xφ5.3X11)	6	SUS304	M6X55	P9119009	
03	REAR CASING	1	PPS	φ123.5X75	A2302131	04-4	IMPELLER COVER	1	PPG	φ100X20	P2452117	08	O. RING	1	FKM	φ109.4Xφ3.1	G110
02-1	FRONT THRUST PAD	1	CERAMIC	φ40X7	P2222106	04-3	INNER MAGNET	1	FERRITE	φ50X50	P2442113	07	BACK UP RING	1	SUS304	φ98X4.5	P2112067
02	FRONT CASING	1	PPG	φ123.5X87.5	P2202061	04-2	MOUTH RING	1	ROLON	φ34X5	P2422112	06	BEARING	1	CERAMIC CARBON	φ25X35	P2462956 A2462217 P2462065
01	MOTOR	1	90W, 2P 3φ 200/400V/220/380V			04-1	IMPELLER VANE	1	PPG	φ100X76.5	P2412111						
						04	IMPELLER ASS'Y	1	PPG	φ68X60.5	P2402063						
						03-3	O. RING	1	FKM	φ13.8Xφ2.4	P14	05-2	OUTER MAGNET	1	FERRITE	φ80X50	P2522116

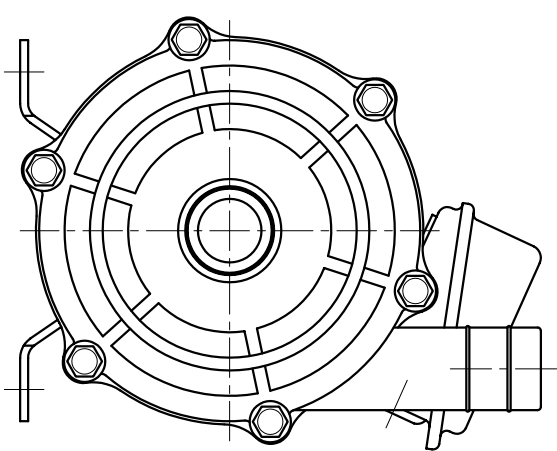
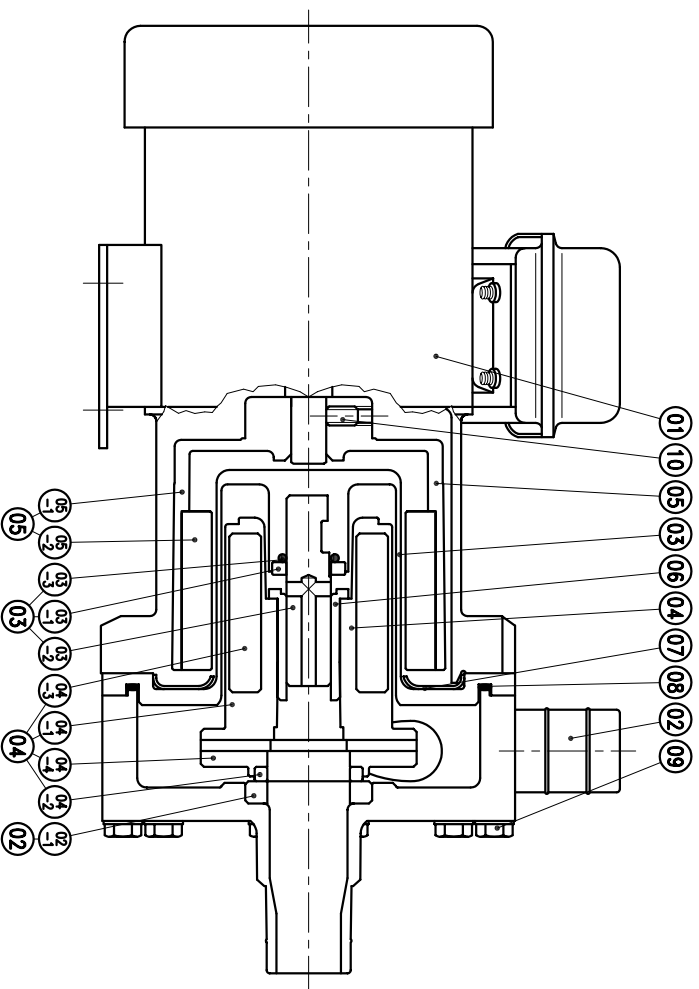

G : 1"X 1"
NPT : 1"X 1"

APPROVED	MDL NAME	NH-150PS-3
CHECK	DWG. NAME	CONSTRUCTION DRAWING
DESIGN	DWG. NO.	E2152114
DR.BY		A3
EDITION		

TPW
HONG YUAN

PAN WORLD CO., LTD.
パンワールド株式会社