

NO	PART NAME	Q'TY	MATERIAL	NOTE	PART NO.
01	MOTOR	1	350W , 2P		
02	FRONT CASING	1	PPG	HOSE THREAD	
03	REAR CASING	1	PPG	φ149X93.5	
04	IMPELLER ASS'Y	1	PPG		
05	OUTER DRIVE RING	1	ADC-12	φ117.5X119	100301800

NO	PART NAME	Q'TY	MATERIAL	NOTE	PART NO.
06	BEARING ASS'Y	1	CERAMIC RULON CARBON	φ44X31	1003010812 1003010811 1003010810
07	INNER DRIVE RING	1	PPG	φ79.6X71	
08	BACK UP RING	1	SUS304	φ140X5.5	
09	O. RING	1	FKM	G130	
10	HEXAGON HEAD BOLT w/t PLAIN WASHER	1	SUS304	M8X50	
11	SET SCREW	2	S435	M8X10	

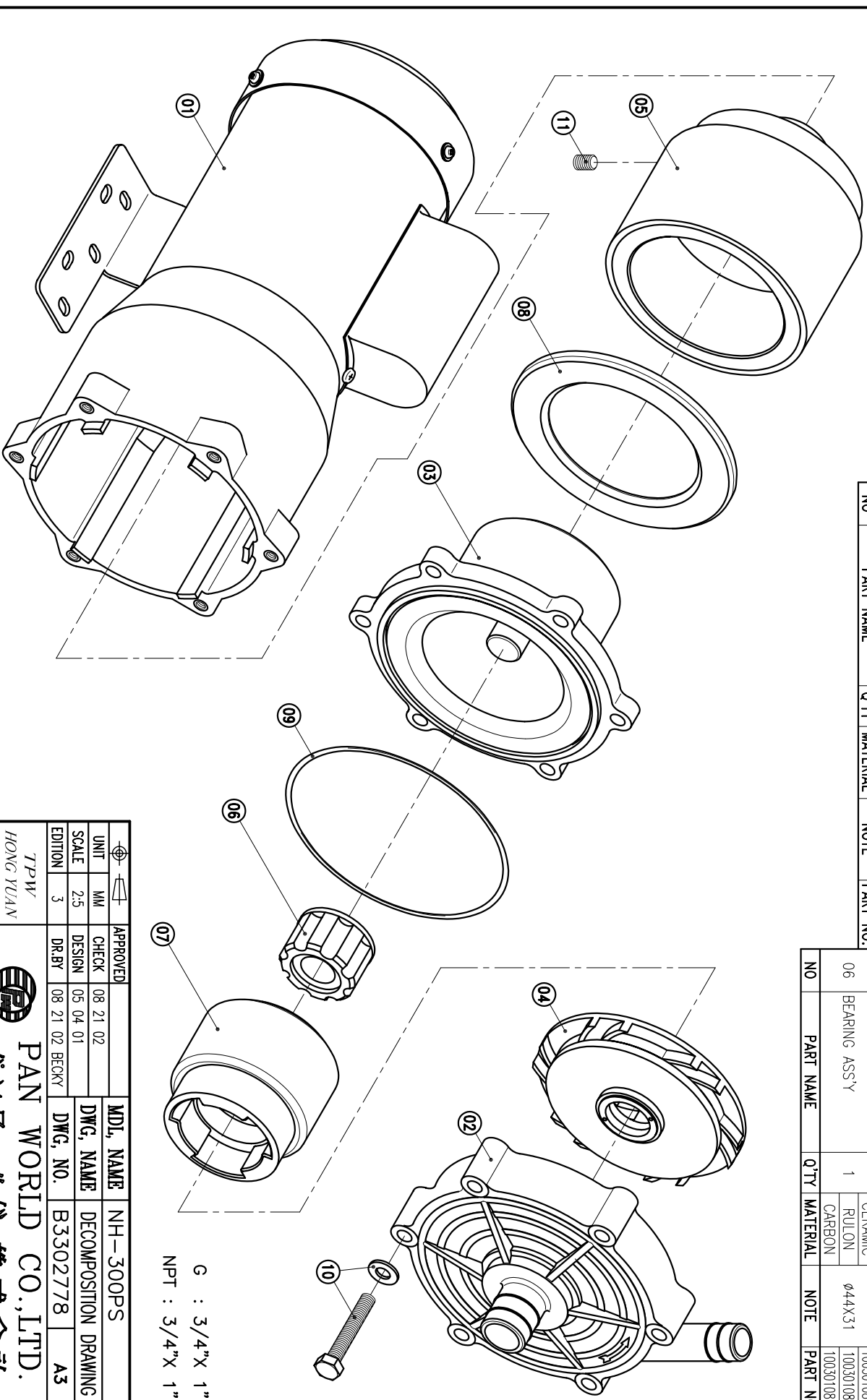

G : 3/4" X 1"
NPT : 3/4" X 1"

APPROVED	CHECK	08 21 02	MDL NAME	NH-300PS
UNIT	MM		DWG. NAME	DECOMPOSITION DRAWING
SCALE	2.5		DESIGN	05 04 01
EDITION	3		DR.BY	08 21 02 BECKY
			DWG. NO.	B3302778
				A3

TPW
HONG YUAN



PAN WORLD CO., LTD.
パンワールド株式会社